

# TERMINATOR-2000®

## OPERATION AND MAINTENANCE MANUAL

*Read this Manual before you operate or service the equipment.*

Carpet and Tile Removal Machinery  
Innovatech Products & Equipment Co.  
19722 144<sup>th</sup> Ave NE  
Woodinville, WA 98072 USA  
Telephone (425) 402-1881  
1-800-267-6682  
Fax (425) 402-8547  
Email: [sales@the-terminator.com](mailto:sales@the-terminator.com)

# TERMINATOR-2000® THE PROFESSIONAL CARPET AND TILE REMOVAL MACHINE



TERMINATOR-2000

<b>INTRODUCTION</b>	<b>5</b>
ABOUT THIS MANUAL .....	6
TERMINATOR® SPECIFICATIONS .....	6
TOOLS AND SUPPLIES .....	6
<b>SAFETY INSTRUCTIONS</b>	<b>7</b>
GENERAL GUIDELINES FOR SAFE OPERATION .....	7
GENERAL OPERATING INSTRUCTIONS FOR THE TERMINATOR® .....	7
SAFETY FEATURES .....	7
SAFETY WARNINGS! .....	8
VENTILATION REQUIREMENTS .....	9
GUARDS, WARNING NOTICES AND SIGNS .....	11
SERVICE INSTRUCTIONS AND PERSONNEL .....	11
REPLACEMENT PARTS AND MATERIALS .....	11
<b>UNCRATING THE TERMINATOR® AND PREPARING IT FOR OPERATION</b>	<b>12</b>
LOADING/UNLOADING PROCEDURES: .....	12
<b>COMPONENTS AND OPERATING SYSTEMS</b>	<b>14</b>
ENGINE AND FAN .....	14
OPERATOR CONTROLS .....	15
IGNITION AND FAN SWITCHES .....	16
SYSTEM GAUGES .....	16
BLADE ASSEMBLY .....	16
BALLAST .....	18
TRICYCLE OR CASTER WHEELBASE AND TIRES .....	18
HOOD AND OPERATOR SEAT .....	19
GEL-CELL BATTERY .....	19
POINTS AND CONDENSOR (H2O ENGINES) .....	20
AIR FILTER .....	20
HYDRAULIC FLUID CARTRIDGE .....	20
FUEL SYSTEM .....	20
START OF DAY OR SHIFT .....	21
CLOSE OF DAY OR SHIFT .....	21
<b>MAINTENANCE PROCEDURES FOR THE TERMINATOR®</b>	<b>22</b>
TROUBLE-SHOOTING * .....	22
LIFETIME MAINTENANCE .....	23
LP GAS EQUIPMENT CORPORATION .....	24
WARRANTY .....	24
IMPCO FUEL SYSTEM ADJUSTMENT INSTRUCTIONS .....	26
SUPPLEMENTARY INSTRUCTIONS FOR DATSUN FORKLIFTS .....	28
TERMINATOR® TUNE-UP SPECS/H2O – II (ELECTRONIC IGNITION) .....	31
TROUBLE SHOOTING GUIDE .....	32
BLADE SELECTION GUIDE .....	33
TERMINATOR® MAINTENANCE SCHEDULE .....	34
MATERIAL SAFETY DATA SHEET .....	40
PROPANE SAFETY PRECAUTIONS .....	42

<b>WARRANTY</b>	<b>44</b>
<b>TERMINATOR 2000 PARTS CATALOG</b>	<b>45</b>
<b>TERMINATOR 2000 PARTS LIST</b>	<b>46</b>
T-2000 HYDRAULIC ASSEMBLY .....	46
T-2000 ENGINE ASSEMBLY .....	48
T-2000 FRONT CONSOLE .....	50
T-2000 WHEEL MOTOR ASSEMBLY .....	52
T-2000 TOP COVER ASSEMBLY .....	54
T-2000 DOOR ASSEMBLY .....	56

**TABLE OF FIGURES**

FIGURE 2: ENGINE AND FAN .....	14
FIGURE 3: OPERATOR CONTROLS .....	15
FIGURE 4: CONTROL CONSOLE .....	16
FIGURE 5: BLADE ASSEMBLY .....	17
FIGURE 6: FRONT BALLAST .....	18
FIGURE 7: REAR BALLAST .....	18
FIGURE 8: FRONT CASTER WHEEL .....	18
FIGURE 9: REAR WHEEL .....	18
FIGURE 10: HOOD AND OPERATOR SEAT .....	19
FIGURE 11: GEL-CELL BATTERY .....	19

## INTRODUCTION

The Terminator® Carpet and Tile Removal Machine is intended for use on large demolition and asbestos abatement projects as well as smaller floor covering removal jobs. Designed and built by experienced floor covering demolition and installation experts, the machine incorporates several design features that are essential for efficient operation:

**Tricycle wheelbase and short turning radius** allows for better turning ability – especially in narrow spaces.

**Blade vertical and tilt position adjustments** allow for positioning the angle of the blade for each application.

**Ballast in front and rear** provides extra traction needed for tile and glue removal.

**Gel-cell battery** provides durable and reliable performance.

**Built-in forklift transport slots** allows for easy loading and unloading at job sites.

**Propane powered engine** provides high fuel efficiency and low air pollution. Propane does however produce carbon monoxide and other gases, which may be harmful to your health if not used in well-ventilated areas. See the Ventilation Requirements.

**Catalytic Converter** provides high fuel economy and lowers emission of harmful gasses.

If operated and cared for as instructed in this Manual, the Terminator® provides trouble-free, safe, and efficient performance.

**About This Manual**

This Manual contains the information and procedures to assist you to operate and maintain the Terminator® machine safely and correctly. **Read this Manual before you operate or service the equipment.** If you need additional information or assistance, please get in touch with our Customer Service Department:

Innovatech Products & Equipment Co.  
 19722 144<sup>th</sup> Ave. NE  
 Woodinville, WA 98072 USA  
 (425) 402-1881 or 800-267-6682  
 Fax (425) 402-8547  
 Email: [sales@the-terminator.com](mailto:sales@the-terminator.com)

NOTE: *Throughout this Manual directional instructions (left, right, up, down, push, pull, etc.) are given from the point of view of the operator performing the action.*

**Terminator® Specifications**

<b>Element</b>	<b>English</b>	<b>Metric</b>
Dimensions		
Width	26 inches	660 mm
Length	65 inches	1651 mm
Height	47 inches	1194 mm
Weight (uncrated)	2500 pounds	1136 kg
Blades are sold individually	.075 inches thick and .095 inches thick combined	1.65 mm 2.41 mm
Rear tires are solid rubber, tubeless, white	15" x 8" x 11¼"	
Engine	Nissan H20 4 cylinder, set at 3500 rpm Uses 30 weight engine oil	Not Applicable
Gel-cell battery	12 volts	Not Applicable
Operating speed	Idle 950-2000 rpm	Not Applicable
Propane tank	3 Gallon capacity, approx. 4 hours operating time	11.3 Liters

**Tools and Supplies**

Maintenance tools and supplies are not provided with the machine. You are responsible for purchase of these items. The following are suggested items to have on the job site.

- |                                    |                               |
|------------------------------------|-------------------------------|
| 1.) 4" or 7" Grinder               | 6.) WD 40                     |
| 2.) 10"-15" Crescent Wrench        | 7.) ¾ Open End and Box Wrench |
| 3.) 16-20 oz. Hammer               | 8.) Screw Driver Set          |
| 4.) Socket Set ¼ - ¾; 3/8 set or ½ | 9.) Safety Glasses            |
| 5.) Grease Gun                     | 10.) Ear Plugs                |

## SAFETY INSTRUCTIONS

The Terminator® is designed for safe operation by trained, designated personnel. To help ensure your safety as a designated operator, **read these safety instructions before you operate the equipment.** Regardless of your experience with machinery, the Terminator® has unique features and systems which you need to know about and understand before you operate or service the machine.

### General Guidelines for Safe Operation

- The Terminator® is to be operated only by qualified, trained personnel.
- Adequate ventilation must be provided when running the Terminator®.
- Use the Terminator® only for the purpose for which it was designed. Attempting to alter the Terminator® will invalidate applicable warranties and possibly damage the machine.
- DO NOT use the Terminator® on roofs or floors not designed to carry the weight of the machine. The Terminator weighs 2,500 lbs.
- Familiarize yourself with all safety features and controls before each use.
- Reduce speed next to walls, machinery and other objects.
- Pre-survey the floor for cracks, ditches, or trenches which could catch the blade of the machine.

### General Operating Instructions for the Terminator®

- The Terminator® is designed to remove carpet, tile and glue residue from floors.
- Position removed product so it rolls to the side of the machines or is removed by employees standing or walking at the side of the machine. NEVER WALK IN FRONT OF BEHIND THE TERMINATOR® WHILE IT IS RUNNING.
- Sharpen blades or dice material into narrower widths if machine slows down or seems to be struggling.
- Do not use the Terminator® within one foot of walls or stationary objects. Damage to objects may occur if the Terminator strikes them®.
- Use safe, OSHA approved tools and methods for sharpening blades.
- Make sure the Terminator® has a charged fire extinguisher, working back up beacon, and is in a properly ventilated area before operating.

### Safety Features

The Terminator® is equipped with several features to help ensure your safety and the safety of workers around you.

**Warning Light and Back Up Alarm.** An amber light is installed on the top rear section of the hood. When the Terminator®'s ignition is in the ON position, the warning light will flash. When the drive control is set in REVERSE, the BACK UP Alarm sounds to warn people nearby that the machine is backing up.

**Fire Extinguisher.** A fire extinguisher with gauge is installed on the hood behind the operator's seat, within his/her reach. As a safety measure, regularly inspect the gauge and recharge the fire extinguisher as needed to maintain full capacity. **Always** recharge the extinguisher after each use.

**AUTOSTOP.** The Terminator® has two drive levers (black) and a blade height lever (black) located directly below the operator seat. The drive levers control the forward, reverse, left, and right directions of the machine; the blade height lever raises and lowers the blade. You must **push (forward) or pull (reverse) and hold** the levers in position to drive the machine or move the blade in the direction desired. When you release a lever, the Terminator® or blade automatically STOPS and will not move again until you **push/pull and hold** the levers again. However these levers are not meant as breaks. Block wheels with a floor block when stopping on a ramp. Without the floor block the machine will roll forward or backwards on any sloping surface.

## Safety Warnings!

FAILURE TO FOLLOW THESE RULES MAY RESULT IN SERIOUS PERSONAL INJURY OR DEATH.

**EYE PROTECTION** should be worn to provide protection against flying particles both from the front and side of the machine. The operator and others when loading, operating, and servicing this machine should always wear eye protection.

**EAR PROTECTION** should be worn to protect the ears. The working area may include exposure to high noise levels, which can lead to hearing damage.

**PROPER VENTILATION** shall be in place while using the Terminator®. Positive or negative pressure ventilators shall be used in any enclosed space where the Terminator® is operating. Carbon monoxide monitoring must be used whenever the Terminator® is operated in doors. The Carbon Monoxide (CO) generated by propane engines in enclosed spaces can be injurious to your health. Use common sense while loading, operating, and running the machine.

- IF YOU ARE NOT thoroughly familiar with operation of the Terminator®, do not attempt to operate the machine.
- NEVER operate the Terminator® unless every guard, warning notice, or sign is in place.
- DO NOT operate the Terminator® while under the influence of drugs, alcohol or medication.
- DO NOT operate the Terminator® near and open flame or smoking materials.
- DO NOT run the machine onto piles of debris, as this may cause the machines to become unstable and tip over.
- NEVER engage in horseplay.
- DO NOT overreach. Keep proper footing and balance at all times. Use the seat belt on the machine.
- ALWAYS turn the engine and fuel flow control OFF when the machine is not in use.
- NEVER stand directly behind or in front of the Terminator® when the engine is running.
- NEVER put your hands or feet in the blade area when the engine is running.
- DO NOT exceed recommended speed.
- NEVER refuel, lift the hood, inspect the blade, or otherwise service or maintain the Terminator® while the engine is running.
- DO NOT move the Terminator® if the engine lid is open.
- NEVER sit or stand next to, under, or around the Terminator® when it is being transported in a moving vehicle, whether by itself or with other equipment.
- NEVER attempt to use the Terminator® on a non-horizontal surface or turn the Terminator® around on a ramp or hill.



## Ventilation Requirements

- Use machine only in well-ventilated areas.
- When operating this machine indoors be aware that carbon monoxide will accumulate if proper ventilation is not provided.
- When in doubt about ventilation stop operation until you are sure the ventilation is adequate.
- A Carbon Monoxide (CO) monitor is highly recommended to monitor the air whenever the Terminator® is operated indoors.
- Read and understand the following OSHA Fact Sheet regarding carbon monoxide poisoning.

**OSHA FACT SHEETS**  
**CARBON MONOXIDE POISONING**  
**U.S. Department of Labor**  
**Program Highlights**  
**Fact Sheet No. OSHA 92-11**

### WHAT IS IT?

Carbon monoxide -- a colorless, odorless, tasteless gas -- is one of the most common industrial hazards. Mild poisoning can cause such symptoms as nausea, dizziness or headaches while severe poisoning can result in brain or heart damage or even death. This poisonous gas is produced by the incomplete burning of any material containing carbon, such as gasoline, natural gas, oil, propane coal, or wood. Forges, blast furnaces and coke ovens all produce carbon monoxide, but one of the most common sources of exposure in the workplace is the internal combustion engine.

Be suspicious of carbon monoxide poisoning if you develop headache, flushed face, dizziness or weakness. Bear in mind that although carbon monoxide has no telltale odor, it may mix with gases which do have an odor. Thus, the smell of other gases doesn't mean the absence of carbon monoxide.

### ARE YOU LIKELY TO BE POISONED?

If you have a heart condition, your condition may be aggravated by carbon monoxide. Ingestion of barbiturates and alcohol may increase the gas' health effects. Further, smokers will have a higher carboxyhemoglobin than nonsmokers, and therefore face higher risk from carbon monoxide exposures on the job.

Harmful levels of carbon monoxide are a potential danger to: acetylene workers, blast furnace workers, boiler room workers, brewery workers, carbon black makers, coke oven workers, customs workers, diesel engine operators, dock workers, garage mechanics, metal oxide reducers, miners, organic chemical synthesizers, petroleum refinery workers, pulp and paper workers, steel workers, toll booth and tunnel attendants, and warehouse workers.

### HOW DOES CARBON MONOXIDE HARM YOU?

Large amounts of carbon monoxide can kill in minutes. The more carbon monoxide in the air and the longer you are exposed to it, the greater the danger. Any one or more of the following symptoms can signal carbon monoxide poisoning: headaches, tightness across the chest, nausea, drowsiness, inattention or fatigue. As the amount of carbon monoxide in the air increases, more serious symptoms develop such as lack of coordination, weakness and confusion.

The poisoning can be reversed if caught in time. But even if you recover, acute poisoning may result in permanent damage to the parts of your body which require a lot of oxygen, such as the heart and brain. There is a significant reproductive risk involved with carbon monoxide. An American Journal of Industrial Medicine article quotes two studies showing that acute carbon monoxide exposures that were non-lethal to the mother were associated with fetal loss.

### WHAT CAN YOU DO ABOUT CARBON MONOXIDE?

If you suspect carbon monoxide, get out of the area and into the open fresh air. Remove anyone overcome by the gas immediately and give the person artificial respiration. Call for a doctor and continue the artificial respiration until the doctor arrives or the person recovers. Prompt action can make the difference between life and death.

#### HOW CAN POISONING BE PREVENTED?

##### Suggestions for Employers

- 1.) Install an effective ventilation system to remove poisonous carbon monoxide from the area.
- 2.) Maintain appliances and equipment in good order, adjusting flames, burners and drafts to reduce the formation of carbon monoxide.
- 3.) Consider switching from fossil fuel-powered equipment to battery-powered machinery when possible.
- 4.) Provide approved respirators for emergency use. Regular respirators (negative pressure) will not work in this atmosphere. If necessary, provide an independent air supply to workers.
- 5.) Install carbon monoxide monitors or regularly test air in areas when carbon monoxide is generated or used.
- 6.) Provide pre-placement and periodic medical examinations for workers who may be exposed to carbon monoxide. If possible, transfer affected workers to other jobs.
- 7.) Instruct workers in the hazards of carbon monoxide and train them in the proper use of respirators.

##### Suggestions for Workers

- 1.) Report to your employer any condition which might make carbon monoxide form or accumulate.
- 2.) Be alert to ventilation problems, especially in enclosed areas where gases of burning fuels may be released.
- 3.) Report complaints early. Don't overexert yourself if you suspect carbon monoxide poisoning. Physical activity increases the body's need for oxygen and thus increases the danger of poisoning.
- 4.) In you get sick, don't forget to tell you doctor about the possibility of exposure to carbon monoxide.
- 5.) Think carefully about your smoking habits. Tobacco, when burned, releases carbon monoxide which reduces the oxygen-carrying ability of the blood, even before any industrial exposure is added.

#### WHAT ARE THE FEDERAL STANDARDS?

The Occupational Safety and Health Administration (OSHA) standard for exposure to carbon monoxide prohibits workers' exposure to more than 35 parts of the gas per million parts of air (ppm), averaged over an 8-hour workday. There is also a ceiling limit of 200 ppm (as measured over a 15-minute period.)

\* This is one of a series of fact sheets highlighting U.S. Department of Labor programs. It is intended as a general description only and does not carry the force of legal opinion.

## Guards, Warning Notices and Signs

The guards, warning notices and signs are placed on the Terminator® for your protection. If one of them becomes damaged or is lost, call our Customer Service Department to order a replacement.

## Service Instructions and Personnel

Like other machinery, the Terminator® requires regular inspection and maintenance of the engine, the operating systems and other parts. To prolong the safe and efficient operating life of the machine, clean and service it as instructed in the Maintenance section of this Manual.

**Always** use trained personnel to service the equipment. **NEVER** allow anyone to service the equipment who has not been specifically trained to do so.

If you need help with a service or maintenance problem, call our Customer Service Department.

## Replacement Parts and Materials

The Terminator® is designed and engineered to operate safely and efficiently with the parts and materials installed on it in our factory. To ensure the continued safe and efficient operation of the equipment, use replacement parts and materials that meet **both** of the following requirements:

Innovatech must authorize replacement parts and materials solely.

Replacement parts and materials must be identical to the items originally provided with the machine, except as authorized by Innovatech.

**Never** use "equivalent" or substitute parts, except as expressly authorized by Innovatech.

If you fail to obey these restrictions, you may injure yourself, damage the Terminator®, and invalidate applicable warranties.

If you are in doubt about any replacement parts or materials, call our Customer Service Department for assistance.

## UNCRATING THE TERMINATOR® AND PREPARING IT FOR OPERATION

When you receive the Terminator®, inspect the outside of the crate completely, to detect damage to the crate itself. If it is damaged, notify the carrier immediately and follow his/her instructions to file a claim.

Carefully uncrate the machine and inspect it for damage that may have occurred during shipping. If the shipment is damaged, notify the carrier immediately and file a claim in the normal manner.

Remove the crate debris, set aside the blades and other packages, and prepare the Terminator® for operation:

To remove the TERMINATOR® from crate with a forklift:

- 1.) Remove footrest: pull clevis pin out (located on the right hand side), this exposes forklift slots.

To remove the TERMINATOR® manually:

- 1.) Put on full propane tank.
- 2.) Take 2 x 4's off the edge of the crate and between the wheels.
- 3.) Place 2 x 4's behind the crate of the rear of the machine.
- 4.) Make a ramp with the 2 x 4's and the crate material.
- 5.) Start the TERMINATOR® (Do Not sit on the machine).
- 6.) Lift front wheel off of the crate 5 in. (jaw will be on crate). Remove feet from area.
- 7.) With right and left lever pull up and move both levers back slowly. The machine will start moving slowly backwards.
- 8.) Jaw will roll back on ramp; both wheels have to come off evenly. If no machine will roll to one side. It is extremely important to back up straight
- 9.) As machine rolls back, make sure center wheel clears the crate. If not lift wheel higher (center lever).
- 10.) Once machine is on the ramp slide all the way to the bottom then lift jaw up and set center wheel down to the ground.

\* Whenever mounting or dismounting the TERMINATOR®, ALWAYS turn OFF the engine.

### Loading/Unloading Procedures:

- Do not load or unload the Terminator® on uneven ground, make sure ramps into moving equipment are square to the ground.
- Always turn the engine OFF when you transport the Terminator® by forklift or other vehicle.
- Load and unload the machine with a properly weighted forklift or lift-gate.
- Make sure all safety stops are installed on a lift-gate before loading or unloading.
- Never position yourself under or around the machine while moving it with other machinery.
- Park the machine with the blade completely down after loading.
- Properly secure the machine with chains, tire chocks, and other necessary tie downs.
- Never ride in a moving vehicle next to a Terminator®. It may tip, causing severe injury.

Using a clean cloth, wipe the shipping dust off the machine, paying particular attention to the operator seat and the gauges on the control panel. Install the fire extinguisher in the clamp behind the operator seat, if they are removed.

Inspect the lug nuts on the rear wheels; tighten the nuts to 70 inch-pounds torque.

Raise the hood and prop it open with the hood brace. Be sure the tip of the brace is firmly secure under the latch. **DO NOT MOVE MACHINE WITH THE LID OPEN!**

Using the respective dipstick, test the oil level of the engine oil and the hydraulic oil (fluid). Add oil and hydraulic fluid, if needed.

Inspect the fuel system connectors and the valve; make sure the valve is OFF.

Have two tanks of propane on hand: one to install and one in reserve. (Each tank provides approximately 3 to 4 hours operating time.)

**CAUTION! Wear insulated gloves and handle the propane tanks and fuel with extreme care, according to the manufacturer's instruction.**  
**DO NOT WORK WITH PROPANE NEAR A FLAME OR SPARKING EQUIPMENT.**

Drive or transport the Terminator® to the work site: (first time drivers see page 17)

For Model 2 machines –

If you drive to the site, check the ignition switch and all fuel flow connections to make sure they are OFF. At the jobsite, install a tank of propane, check the fuel system connectors again, turn the flow switch ON, remove the hood brace from the locking bracket, lower the brace to its down position, lower the hood and lock it in place.

Start the engine and let it idle for a few minutes. Raise the blade jaw a few inches to clear the floor and avoid damage to the blade in transit.

If you transport the Terminator® by forklift or truck, anchor the machine in place with chains, wheel locks, or other tie down devices.

## COMPONENTS AND OPERATING SYSTEMS

The major components and the operating systems of the Terminator® are discussed in detail below.

### Engine and Fan

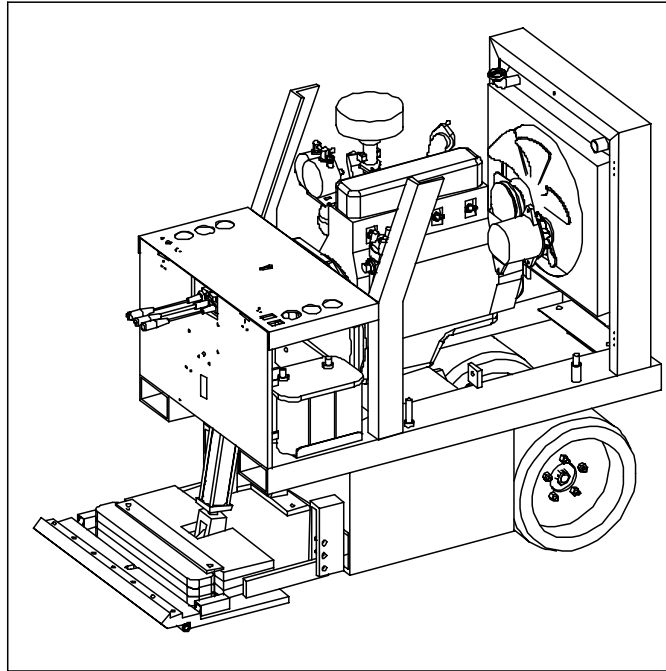

Figure 2: Engine and Fan

The propane-powered engine and fan are located under the hood. The engine provides the power to drive the Terminator®.

The fan ventilates and cools the entire engine and fuel tank area on the older models. A safety guard covers the fan. **NEVER operate the machine unless the guard is in place. If you remove the guard to clean the fan, replace the guard before you start the engine again. ALWAYS keep your hands away from the fan when the engine is running.**

The engine requires regular inspection and service, to maintain its efficiency and prolong its operating life. Check the oil level and clarity daily. Change the oil every 60 hours of running. **Do not allow the oil to get muddy before changing it because dirty oil can damage the engine and its parts** (see the Maintenance section for details). If operating machine in very dusty areas, change oil every 40 hours.

Air filter should be checked every day if machine is run 4 or more hours, to make sure it is clean. Blow dust out or replace with another filter.

### Operator Controls

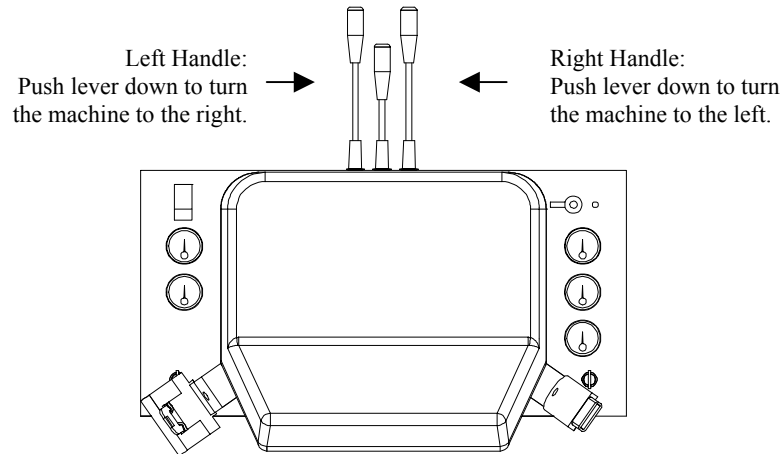

Figure 3: Operator Controls

The operator controls consist of the drive and blade height levers, ignition and fan switches.

The DRIVE AND BLADE CONTROLS (three levers) are located directly in front of the operator seat. The drive levers (left and right) control the motion of the rear wheels. The blade height lever (center) controls the vertical position of the blade. Use these controls as follows:

From the view of the seated operator:

Push the left and right levers forward **together** and hold them in position = the machine moves forward.

Pull the left and right levers **together** toward you and hold them in position = the machine moves in reverse. (The alarm sounds.)

Push the left lever only = the left rear wheel turns the machine to the right  
 Push the right lever only = the right rear wheel turns the machine to the left.

Push and hold the blade height lever (center) forward to lower the blade; pull and hold the lever toward you to raise the blade.

**AUTO STOP:** When you release a drive or blade lever, the engine continues to run but the drive or blade motion automatically stops and does not start again until you push or pull and hold the lever again.

**First Time Driver:** Lift Blade Jaw off floor 1 ½ inches. Do not put the blade into the jaw until familiar with the machine.

- 1.) Sit on machine and buckle the seat belt. Start engine. With right lever slowly push down, engine's rpm's will lower and the machine will move very little. Hold the levers there.
- 2.) Left lever move slowly and machine will move forward, at that moment push both, left and right levers all the way down.
- 3.) As the machine is moving forward if machine drifts left, raise right lever up a little and machine will straighten out, if the machine drifts to the right lift left lever slightly.
- 4.) Do not pull lever all the way back abruptly because the machine will turn very sharply. If you lift levers to far, let go of both handles and restart with procedure # 1.

Practice turning left, right, and going forward and backwards until you are comfortable driving the TERMINATOR®.

### Ignition and Fan Switches

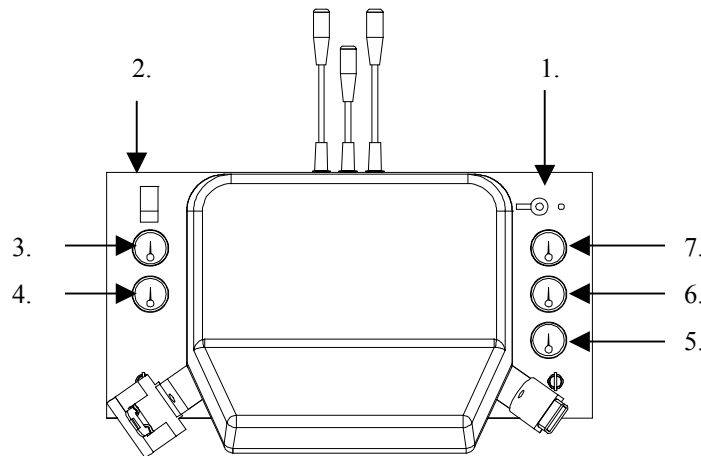

Figure 4: Control Console

- 1.) The IGNITION SWITCH (selector ON/OFF/START) is located in the upper right hand corner of the gauges panel. To START the engine, turn the key switch ON (key switch is on some models). Pause for one or two seconds, turn to START and hold until the engine fires, then release the switch. **ALWAYS turn this switch OFF when the Terminator® is not in use.**
- 2.) The HEADLIGHT SWITCH (ON/OFF toggle) is located on the system gauges panel. **Do not leave the fan switch ON when the machine is not in use.**

### System Gauges

The system gauges monitor the Terminator®’s various operating systems. These gauges are located on the system gauges panel and consist of the following:

- 3.) AMP/ALTERNATOR: shows battery activity.
- 4.) HOUR METER: shows the exact running time of the machine. The hour meter will continue to run while the key and lever ignition switch are on.
- 5.) HYDRAULIC OIL TEMPERATURE (a.k.a. hydraulic fluid): Normal temperatures are below 120°F. Hydraulic fluid temperature exceeding 200°F may damage the hydraulic system and in turn, damage the Terminator®.
- 6.) OIL PRESSURE GAUGE: shows the oil pressure of the engine lubricant. During normal operation, this gauge should register in the safe range shown on the dial (40-60 PSI). If this pressure drops suddenly, shut the engine OFF immediately and check the oil supply. NEVER attempt to operate the Terminator® without adequate oil because you will destroy the engine and its parts. If water or oil temperatures exceed maximum temperature, lift lid and remove side panels. Let run for five minutes. Turn machine off to cool for 30-60 minutes. If possible, let cool by an open outside door or window. Never remove radiator cap if water is boiling out. Always, let the machine cool down.
- 7.) WATER TEMPERATURE GAUGE: normal range is 190°F-230°F. When the machine is new, this gauge may register 220°F-250°F for the first 50± hours of operation. This is the normal break-in period. After this break-in period, the gauge shows the actual temperature of the water.

### Blade Assembly



Blades are available in different configurations and thickness. An assortment of blades is included in the purchase price of the Terminator®. Extra blades are available upon request from Innovatech Products & Equipment Co., Inc.

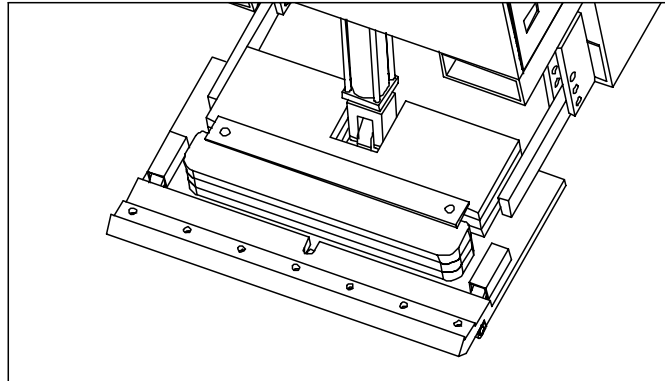

Figure 5: Blade Assembly

### Installing a Blade

- 1.) Lower the blade assembly to maximum down position, which is two inches off the floor.
- 2.) Unwrap the pre-sharpened blades and select the blade thickness and length you need for the job.
- 3.) Loosen the 7 holding bolts.
- 4.) Insert the sharpened blade.
- 5.) Tighten bolts firmly, starting from the center and working out. Bolts should be snug but not over tightened.

### Adjusting Blade Tilt

Loosen the blade angle adjusting bolt and manually move the blade to the desired tilt (angle is set at factor for 80% of the job); tighten the bolt. Raise the blade assembly a few inches to clear the floor and prevent damage to the blade while the Terminator® is in transit.

### Taking Up Floor Coverings

- 1.) Insert blade. (As shown above)
- 2.) Lower blade to floor. As the blade flexes lift caster wheel off the floor  $\frac{1}{4}$  inch. Use previous procedures to drive forward.
- 3.) As the Terminator® is removing flooring material have another person at the side of the machine remove all debris.

### Ballast

The Terminator® is equipped with weights in front (75 pounds each) and rear (125 pounds each) to provide traction for tough jobs. These weights can be removed to reduce traction for certain jobs, and to transport the Terminator® by forklift or truck or elevator. Wear gloves when handling these weights. Use caution to not smash toes and fingers. Use weight procedures from OSHA.

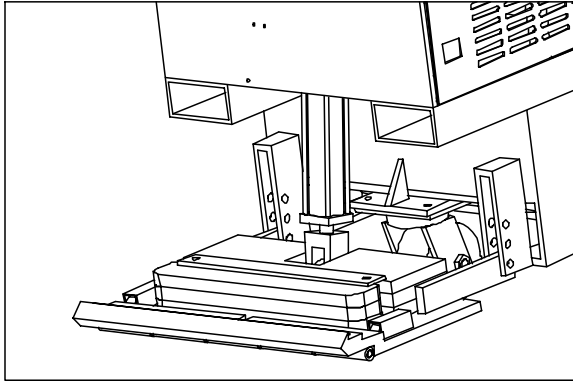

Figure 6: Front Ballast

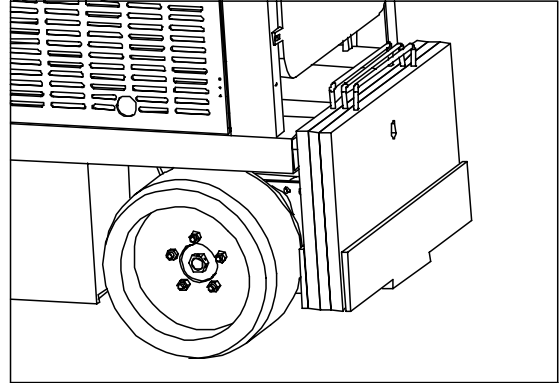

Figure 7: Rear Ballast

### Tricycle or Caster Wheelbase and Tires

The tricycle wheelbase allows better turning ability. The wheel bearings on the front caster roller require lubrication with grease every 30 hours of machine operation. There are three fittings, two on the wheel and one on the housing. When running over debris such as carpet, the carpet yarn will get caught between the wheel and the housing. Clean out wheel and housing regularly.

The rear tires are solid rubber, tubeless, and require no maintenance. Over time, they may wear out and need to be replaced (see the Maintenance section for replacement procedure). Before each job, inspect the rear tires and lug bolts. Tighten the lug bolts as needed to 70 foot-pounds torque. It is important to keep the lug bolts tight.

Wheel hub should be torqued from 250 to 300 foot pounds (ft.lbs.). Inspect and re-torque every 60 hours of operation. Lift machine off of floor so no weight is on wheel when re-torquing pack nut.

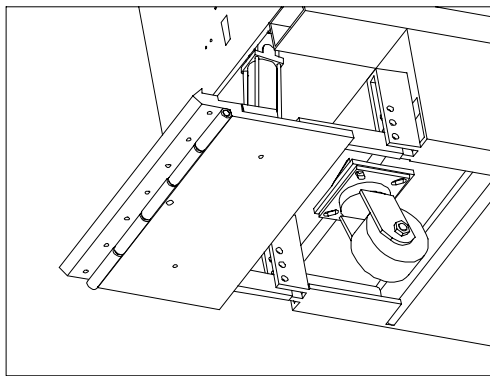

Figure 8: Front Caster Wheel

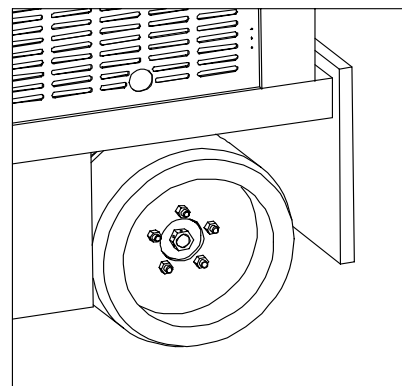

Figure 9: Rear Wheel

## Hood and Operator Seat

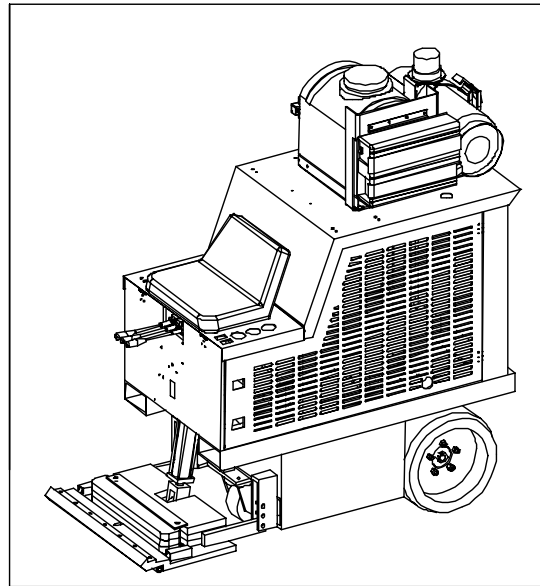

Figure 10: Hood and Operator Seat

The hood covers the engine, fan, fuel supply and their related system. The top of the hood contains the operator seat, fire extinguisher, amber back up light, and the propane tank. The water mister and inverter package are optional accessories. On older models of the Terminator® the hood and seat are removable to aid in transporting the machine in a truck or building elevator.

### Removing the Hood

Remove the 4 bolts and remove the hood.

### Removing the Operator Seat

After you remove the hood, turn the hood on its side and remove the holding nuts and bolts of the seat. Remove the seat. Screw the nuts and bolts back on the seat, to prevent losing them in transit.

## Gel-Cell Battery

The GEL-CELL BATTERY is self-contained and does not require maintenance. In normal operating situations, it has an operating life of about three years. NEVER attempt to use any other type of battery in the Terminator® because you will injure yourself, damage the equipment, and invalidate applicable warranties. When the battery needs to be replaced, call Innovatech Service Department for assistance.

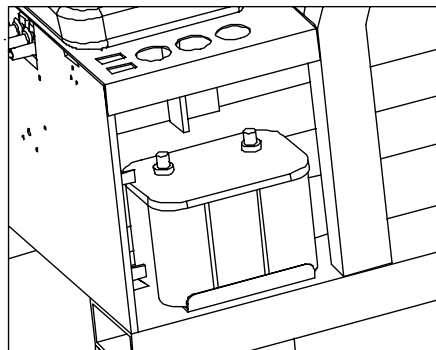

Figure 11: Gel-Cell Battery

## Points and Condenser (H2O Engines)

On older models of the Terminator® the points and condenser are part of the ignition system and need to be replaced annually or every 200 hours running time.

## Air Filter

The air filter helps prevent dust and dirt from entering the engine. Inspect the air filter before operating each day and replace when dirty.

## Hydraulic Fluid Cartridge

Inspect the hydraulic fluid cartridge regularly and replace the filter when it gets dirty. It is recommended that the hydraulic fluid and filter be changed annually and if fluid is overheated 160°F – 180°F or higher. On 2000 models hydraulic filter should be changed every 60 hours when engine oil is changed. For every filter change you lose approximately 1 pint of oil. So on the 8th filter change, you should add one gallon of oil.

## Fuel System

### STOP!

Read the propane material safety data sheets  
and safety rules on pages 42-45 before proceeding.

The fuel system consists of propane tank, fuel lines, connectors, and flow control. The Terminator® is designed to accommodate a three gallon tank, which will usually provide about three to four hours running time. Keep a reserve tank on hand.

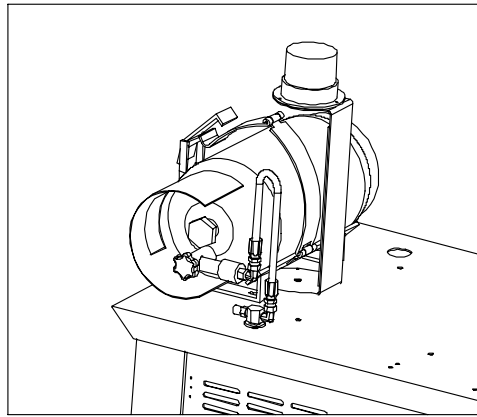

### LPG FUEL CYLINDER REPLACEMENT PROCEDURE

- 1.) NO SMOKING – Do not replace fuel cylinders in areas that have a source of fuel ignition.
- 2.) Close cylinder valve and run engine until it stops prior to disconnecting the fuel hose from the tank.
- 3.) Connect fuel hose. Open valve slowly so the hose and tank pressure can equalize or the valve may slug. Should leakage occur, close valve and have qualified personnel make repairs.
- 4.) Use fuel manufactured National Gas Processors association “HD-5” specification.

NOTE: THE ABOVE IS PROVIDED AS A GUIDE. FOR ADDITIONAL INFORMATION, CONSULT THE NATIONAL FIRE PROTECTION ASSOCIATION PAMPHLET 58 FOR THE SAFE STORAGE AND HANDLING OF LIQUEFIED PETROLEUM GASES.

NOLFF'S Carburetion, Inc. 1-800-451-7040

## START OF DAY OR SHIFT

Use the following procedures to start the day or shift or to set up for a new job.

**All systems are OFF and the fuel flow control is OFF. You are ready to test the Terminator® before starting a job or moving it to a job site.**

- 1.) Check all the fuses located in the console panel.
- 2.) Check all the fuel linkages and lines for leaks that you can see, hear or smell. Turn the propane tank ON (turn control counterclockwise) **very slowly** and listen for leaks (a hiss). If yes, turn the tank OFF, tighten the line and test again.

Control ON: turn control counterclockwise

Control OFF: turn control clockwise

If all linkages and lines are okay, go to Step 3.

- 3.) Use dipsticks to check the level and clarity of the engine oil and hydraulic fluid. Add oil or fluid as needed. If either oil is cloudy or beginning to look muddy, change it before you run the engine. **Do not run the Terminator® on dirty or muddy oil because you can damage the engine and its parts.** Visually inspect air filter and replace if dirty.
- 4.) Check the blade and replace or adjust it as needed for the job.
- 5.) Check the tires.
- 6.) Inspect the machine as a whole; to be sure it is ready to run.
- 7.) Mount machine. Turn keyed ignition On, pause and turn starter ignition switch to start engine.
- 8.) When dismounting machine, turn off engine.

## CLOSE OF DAY OR SHIFT

- 1.) Turn all switches and systems OFF.
- 2.) Turn the propane tank control OFF.
- 3.) Inspect the machine overall to make sure it is okay to run the next day or shift.
- 4.) For safety, remove propane tank and key.

## MAINTENANCE PROCEDURES FOR THE TERMINATOR®

Refer to the Nissan H20 Engine manual for complete maintenance instructions. When working on this machine always take into consideration the warnings about this machine and take extra care when evaluating the problem.

### Trouble-Shooting \*

#### THE MACHINE STOPS OR WON'T START

- 1.) Check all fuses under the console panel.
- 2.) Check the coil, wires, and ignitions system; the battery and cable connectors; and the points and condenser.
- 3.) On some models check the hydraulic fluid cartridge and the red reset button. If the button is OUT, push it IN to reset the hydraulic system.
- 4.) Check propane tank coupler.
- 5.) Wait **at least 5 minutes**, then re-start the Terminator® in the normal way (see page 23 for Start of Day or Shift procedures)

#### THE ENGINE RUNS BUT THE MACHINE WON'T MOVE

- 1.) On some models check the hydraulic fluid diverter. Move the lever to the right or left, if it is set in idle position.
- 2.) Try to drive forward (or reverse) again. If the machine won't move, call our Customer Service Department for assistance.

#### THE BATTERY GAUGE SHOWS NO CHARGE

- 1.) Check the alternator. Check the battery and recharge or replace it, as needed.

#### RUNNING HOT – Breaking in Machine – 250 degrees

- 1.) Check water level. Do not open radiator when hot, allow for it to cool.
- 2.) Check for dirt in radiator (blow out with air or water).
- 3.) Run with side panels off to help cool down.
- 4.) Run machine with hydraulic fan on at all times.
- 5.) Running machine at high rpm's will cause overheating. Allow for a cool down period in your work schedule.
- 6.) The room may need more air movement/circulation.

\* Also see appendix for further troubleshooting information.

### Lifetime Maintenance

- 1.) Grease Caster Wheel at three fittings every 30 hours.
- 2.) Change Engine Oil every 60 hours with 10-30 wt., 10-40 wt., 10-50 wt. Use oil type consistently throughout the life of the machine.
- 3.) Change Oil Filter – Part Number RP2-005 (available from Innovatech).
- 4.) Check Hydraulic Oil Once a week. Change every 18 months with NUTO H 46 or ISO 46 or if fluid is overheated 160°F – 180°F or higher, filter every 60 hours.
- 5.) Check water level once a week. Change every 12 months with a 50/50 mix with antifreeze.
- 6.) Clean Caster Wheel and Back Tires with wire wheel when necessary.
- 7.) Change Air Cleaner when dirty with part number RP2-004 (available from Innovatech).
- 8.) On H-20 machines change points .018” to .022” gap, plugs .028” to .031” gap – type B4ES (Bosch), rotor, distributor cap and condenser every 12 months or 200 hours. Tune Up Kit Number RP2-006 (available from Innovatech). With the H20-II and 2000 models change the plugs, cap, rotor once a year or every 200 hours.
- 9.) Timing should be set between 3° - 8° degrees BTDC.
- 10.) Lube jaw hinge once a week.
- 11.) Look for leaks, find and tighten fittings – do not over tighten fittings.
- 12.) Clean radiator and hydraulic fins with water or air when dirty or dusty. Use caution not to bend fin.
- 13.) Check all hoses and clamps once a week.
- 14.) Inspect rear tires and lug bolts. Tighten lug bolts as needed to 70-foot pounds torque.
- 15.) Check wheel hub every 60 hours of operation. Wheel hub should be torqued from 310 to 350 foot pounds (ft. lbs).

---

**LP-GAS** Equipment Corporation

Main Office

3216 S. Nordic Road  
Arlington Heights, IL 60005  
Telephone: 708-437-2345  
Telefax: 708-437-2350

**LP GAS EQUIPMENT CORPORATION**

**WARRANTY**

LP GAS EQUIPMENT CORPORATION WARRANTS ITS PRODUCTS AGAINST DEFECTS IN MATERIAL AND WORKMANSHIP FOR A PERIOD OF NINETY DAYS. DEFECTIVE MERCHANDISE WILL BE REPLACED WITHOUT CHARGE BUT LABOR CHARGES INCURRED IN THE REMOVAL, DISASSEMBLY OR REINSTALLATION OF SUCH PRODUCTS WILL NOT BE ALLOWED. NO MERCHANDISE CAN BE RETURNED WITHOUT WRITTEN PERMISSION FROM THE FACTORY. TRANSPORTATION CHARGES MUST BE PREPAID. THE FACTORY SHALL BE THE SOLE JUDGE OF DEFECTS IN PRODUCTS RETURNED. A TEN PERCENT HANDLING CHARGE WILL BE MADE FOR ALL MERCHANDISE RETURNED THAT IS NOT DEFECTIVE. ALL PRICES ARE SUBJECT TO CHANGE WITHOUT NOTICE. WE RESERVE THE RIGHT TO LIMIT QUANTITIES AND TO MAKE PARTIAL SHIPMENTS UNLESS SPECIFICALLY INSTRUCTED OTHERWISE. THE OBLIGATION OF THE COMPANY UNDER THIS WARRANTY IS LIMITED TO REPLACING ANY COMPLETE UNITS OR PARTS THEREOF WHICH BY OUR EXAMINATION WE JUDGE TO BE DEFECTIVE.

NOTE: FAILURES CAUSED BY:

- DIRT
- POOR QUALITY FUEL
- ABUSE
- NORMAL WEAR
- DISASSEMBLY

**ARE NOT COVERED BY OUR WARRANTY!**



## RECOMMENDED SAFETY MAINTENANCE PROCEDURE FOR LP GAS FUELED FORKLIFT TRUCKS

**WARNING:** LP GAS is combustible fuel that is heavier than air. Escaping gas may accumulate in low areas. The fuel cylinder should be mounted so that it does not extend outside the truck and should also be properly positioned by using the locating pin or dey way.

The fuel valve should be turned off when the machine is not in service.

Use only Underwriters Laboratories or Factory Mutual listed LP-GAS hose assemblies where pressure fuel lines are required.

All pipe threaded fittings should be installed using an approved sealing compound.

Fuel lines should be supported by clamps to minimize chafing and wear.

The LP-GAS solenoid valve should be wired to an automatic shut off switch (oil pressure or vacuum) to prevent leakage of gas in the event the ignition is on without the engine running.

Check the propane solenoid or vacuum shutoff valve for leakage as follows:

1. Turn fuel cylinder valve off, start and run engine until it stops.
2. Install a 0 to 30 PSI pressure gauge per instruction A or B.
  - A. Primary test prot of single units consisting of primary and secondary regulators.
  - B. Between the primary and secondary stage regulators when the propane system consists of two separate regulators.
3. Turn cylinder fuel valve on. The pressure gauge should maintain a zero reading. If it does not, the solenoid valve or vacuum shut off valve must be repaired or replaced.

An odor is added to LP-GAS to help detect leaks. If the gas odor is detected the fuel cylinder supply valve and engine should be turned off. Remove all sources of ignition, and ventilate the area. Make all of the necessary repairs before you turn the fuel supply on.

The complete LP-GAS system should be inspected periodically. Check all hoses for wear, connections for leaks and all parts for damage.

**NOTE:** Fuel hoses have a limited life expectancy. They should be checked for cracking and drying due to age. Hoses with visible signs of age should be replaced. Use only Underwriters Laboratories or Factory Mutual listed LP-GAS parts for replacements.

**NOTE:** The above information is provided as a guide. Consult the National Fire Protection Association pamphlet 58 for the safe storage and handling of liquefied petroleum gases.

Governmental safety regulations in your locality could vary. Check with the authority having jurisdiction to be sure that you meet all of their requirements. Contact the manufacturer for detailed service information.

**SERVICE WORK SHOULD BE PERFORMED BY  
QUALIFIED PERSONNEL ONLY**

**LP-GAS EQUIPMENT CORPORATION**

## **IMPCO FUEL SYSTEM ADJUSTMENT INSTRUCTIONS**

1. BE SURE THAT WATER HOSES, FUEL HOSES AND WIRES ARE PROPERLY FASTENED IN PLACE. THEY SHOULD BE CLEAR OF EXHAUST SYSTEM AND SHARP OBJECTS.
2. BEGIN TO PRESSURIZE THE FUEL SYSTEM BY OPENING THE FUEL CYLINDER HAND VALVE SLOWLY AND CONTINUE AS FOLLOWS:
  - A. SYSTEMS WITH VACUUM OPERATED SHUTOFF VALVES SUCH AS THE IMPCO VFF30 MUST HAVE VACUUM APPLIED TO THE VALVE TO ALLOW FUEL TO PASS THROUGH TO THE VAPORIZER-REGULATOR. THIS CAN BE DONE BY OPERATING THE ENGINE CRANKING MOTOR.
  - B. SYSTEMS WITH ELECTRICALLY OPERATED SHUTOFF VALVES MUST HAVE CURRENT TO THE VALVE BEFORE IT OPENS AND ALLOWS FUEL TO PASS THROUGH. A VACUUM SWITCH OR OIL PRESSURE SWITCH MUST BE USED AS AN ADDITIONAL SAFETY AND SITED IN SERIES WITH THE ELECTRIC SOLENOID. ACTUATING EITHER OF THESE CAN BE DONE WITH THE CRANKING MOTOR. IT MAY TAKE MORE CRANKING TO ACTUATE THE OIL PRESSURE SWITCH.
3. CHECK ALL OF THE FUEL CONNECTIONS FOR LEAKS WITH AN APPROVED LEAK CHECK SOLUTION THAT CAN BE ORDERED FROM YOUR LPG PARTS SUPPLIER.
4. THE FUEL CYLINDER MUST BE LOCATED WITHIN THE OUTER LIMITS OF THE MACHINE.

### **BEFORE YOU MAKE ANY FUEL ADJUSTMENTS:**

1. THE AIR CLEANER SHOULD BE INSTALLED.
2. IGNITION TIMING MUST BE CHECKED AND ADJUSTED PER THE ENGINE MANUFACTURER'S SPECIFICATIONS. PROPANE BURNS SLOWER THAN GASOLINE. RETARDED TIMING WILL REDUCE HORSEPOWER AND INCREASE EXHAUST EMISSIONS. MOST MANUFACTURERS RECOMMEND ADVANCING THE TIMING 3 TO 5 DEGREES. THIS WILL INCREASE LOWER END TORQUE HORSEPOWER; HOWEVER YOU MAY EXPERIENCE A LOSS OF POWER UNDER EXTREME HEAVY LOAD CONDITIONS. WHEN MACHINES ARE WORKED VERY HARD, BE CAREFUL NOT TO ADVANCE THE TIMING BEYOND THE MANUFACTURER'S RECOMMENDATION. THIS WOULD CAUSE UNNECESSARY STRESS ON THE ENGINE.
3. CONVERTING ENGINES TO BURN PROPANE MAY CAUSE THE GOVERNED ENGINE SPEED TO CHANGE. TO MAINTAIN THE TRUCK'S "NO LOAD" AND "LIGHT LOAD" DRIVABILITY, IT MAY BE NECESSARY TO RESET THE GOVERNOR TO FACTORY SPECIFICATIONS. THE ENGINE MUST BE AT ITS NORMAL OPERATING TEMPERATURE PRIOR TO MAKING ANY ADJUSTMENTS.
4. THE ENGINE AND TRANSMISSION SHOULD BE AT OPERATING TEMPERATURES.

### **POWER ADJUSTMENT:**

FULL POWER MIXTURES ARE CONTROLLED BY THE MIXTURE ADJUSTMENT AT THE FUEL INLET OF THE MIXER. THE FUEL MIXER CASTING IS MARKED WITH AN "R&L" INDICATIONS THE FULL, RICH AND LEAN POSITIONS OF THE VALVE. THIS ADJUSTMENT WILL CONTROL THE FULL LOAD FUEL MIXTURE AND MUST BE MADE WITH THE ENGINE UNDER FULL OR WORKING LOAD.

### **IDLE ADJUSTMENT:**

TURNING THE SCREW "IN" WILL MAKE THE FUEL MIXTURE RICHER AND TURNING IT "OUT" WILL MAKE IT LEAN. THIS ADJUSTMENT MUST BE MADE AT THE MANUFACTURER'S RECOMMENDED IDLE RPM.

**WE STERNLY RECOMMEND THAT YOU USE A CARBON MONOXIDE FUEL ANALYZER TO ADJUST THE FUEL MIXTURE.**

### **READINGS USING CARBON MONOXIDE ANALYZER:**

POWER MIXTURE - .1 TO .2 PERCENT  
IDLE MIXTURE - .5 TO .75 PERCENT

### **READINGS USING AIR FUEL RATIO ANALYZER:**

POWER SETTING - 15.5 - 16 TO 1  
IDLE SETTING - 14.5 TO 1

NOTE: WHEN EXHAUST ANALYZERS ARE NOT AVAILABLE, A TACHOMETER MAY BE USED.

MAKE FUEL ADJUSTMENTS TO OBTAIN MAXIMUM RPM READING, THEN LEAN FUEL MIXTURE TO LOWER READINGS TO 10 - 20 RPM.

## **IMPORTANT !**

### CARBON MONOXIDE – WHAT SERVICE PERSONNEL SHOULD KNOW!

#### OSHA REQUIREMENT

THE CO LEVEL SHALL NOT EXCEED 35 PPM MEASURED OVER AN 8-HOUR PERIOD IN THE WORK ENVIRONMENT.

HOW DOES PARTS PER MILLION (PPM) RELATE TO PERCENTAGE NUMBERS?

ONE MILLION PARTS PER MILLION EQUALS ONE HUNDRED PERCENT OF THE ENGINES EXHAUST GASES.

- ◆ 10% CO EQUALS 100,000 PPM
- ◆ 1% CO EQUALS 10,000 PPM
- ◆ .1% CO EQUALS 1,000 PPM
- ◆ .01% CO EQUALS 100 PPM

FOR EACH ONE ONE-HUNDREDTH OF ONE PERCENT YOU WILL HAVE 100 PPM.

EXAMPLE: .01% X 1,000,000 PPM CO = 100 PPM CO.

WITH ADEQUATE VENTILATION AND FOLLOWING THE ENCLOSED ADJUSTMENT INSTRUCTIONS, YOU SHOULD BE ABLE TO KEEP THE CARBON-MONOXIDE LEVEL BELOW THE OSHA REQUIREMENT.

**WE STRONGLY RECOMMEND THE USE OF A  
CARBON MONOXIDE ANALYZER**

## **SUPPLEMENTARY INSTRUCTIONS FOR DATSUN FORKLIFTS**

“IF THE DATSUN MODEL FORKLIFT YOU ARE CONVERTING FROM GAS TO LP DOES HAVE A VACUUM SOLENOID WITH THREE HOSES CONNECTING TO IT AND AN ELECTRONIC PULSER CONNECTED TO THE SOLENOID, THEY BOTH MUST BE REMOVED AND DISCARDED.” THE LONGER OF THE HOSES IS USED BY CONNECTING THE END TO THE DISTRIBUTOR VACUUM ADVANCE AND THE OTHER END TO THE LPG CARBURETOR.

### **SUPPLEMENTARY INSTRUCTIONS**

**FOR**

**1982 DATSUN FORKLIFTS**

**WITH MODEL H20 ENGINE**

IF THE ENGINE IS EQUIPPED WITH A FORMED ELBOW TYPE HOSE AT THE TOP OF THE WATER PUMP, INSTEAD OF A FITTING, YOU MUST CUT THE RUBBER HOSE SO THAT 4” OF HOSE REMAINS AT THE TOP OF THE WATER PUMP CONNECTION. THE 4” OF HOSE IS NEEDED TO MAKE YOUR WATER CONNECTION AND TO GAIN PROPER CLEARANCE BETWEEN THE WATER HOSE AND THE EXHAUST MANIFOLD PIPE. INSERT HOSE UNION AND CONNECT THE WATER LINE FROM THE VAPORIZER USING TWO CLAMPS TO SECURE THEM.

**Impco L.P. Gas Kit Installation Instructions**

**DATSUN**

**C 4000, 5000, 6000**

**P 4000, 5000, 6000**

**H-20 Engine**

The following instructions give a general outline of installation procedures on converting Industrial Trucks to LP gas operation. They are supported with additional sheets, including drawings where applicable.

These instructions are brief for simplicity and we recommend that installation and service personnel be aware of safety regulations as outlined in the national Fire Protection Association pamphlets 58, 37, and 505. There

may be additional governmental recommendations and safety rules in your locality which must be met in addition to the above, so be aware of these facts. These systems include all safety equipment required for complying with these regulations and additional information will be furnished if it is necessary.

Remember, safety first, and when in doubt, please ask for clarification.

#### I. PRELIMINARY STEPS

1. Drain Gasoline tank and run engine until it stops.
2. Disconnect battery leads.
3. If at all possible, gasoline tank should be removed.  
If not removed, plug the gasoline tank inlet and outlet openings. Sending unit is to be removed and replaced with sending unit cover. It should be filled with noncombustible material that will not freeze if left outdoors. Replace existing fuel cap with pipe cap supplied in kit.
4. Drain radiator. Observe its general condition and clean if required.

#### II. REMOVE THE FOLLOWING

1. Gasoline fuel lines and fuel pump.
2. Gasoline carburetor and choke cable assembly.
3. Water hoses between the intake manifold and the cooling system.

#### III. CHECK THE FOLLOWING

1. Be sure pipe cap that is supplied in kit is securely fastened on fuel tank.
2. The sending unit is removed and the cover plate is installed.

#### IV. INSTALL THE FOLLOWING

1. Fuel pump cover and gasket. Clean surfaces of all old materials.
2. Install gasoline gauge decal over gasoline gauge on instrument panel.
3. Loosen and remove two engine. Mount bracket which is attached to vaporize/regulator and fuel lock filter assembly to head bolts. Retorque head bolts at Mfg. Specs.
4. Water hose from the regulator to the water pressure supply tube which originally supplied the intake manifold.
5. Water hose from the regulator to the suction tube above the lower radiator hose. Secure water hoses together with nylon strap which is provided.
6. Clean intake manifold flange and install carburetor assembly per the attached drawing. The throttle linkage will now run parallel to the engine.
7. Distributor vacuum advance hose.
8. Vacuum hose VFF-30 lockoff of carburetor.
9. Dry gas hose-regulator to carburetor.
10. Remove bolt at intake manifold and install throttle return bracket.
11. Throttle return spring between spring bracket and carburetor throttle lever.
12. Make sure throttle is opening correctly to the "wide open" position.
13. Install bulkhead relief valve assembly per the attached drawing #5.
14. Install fuel line from the vacuum fuel lock filter to the bottom side of the bulkhead assembly. Use misc. brass fittings in misc. box. Also, use support bracket to support hose. Remove bolt at air cleaner base and install bracket. Make sure the fuel line remains clear of sharp objects.
15. Mount cylinder brackets to support plate per attached drawing #4. Use long bolts to mount bracket assembly to truck. **Please note: each bolt requires 2 flatwashers to be installed on bottom side of counterweight. IMPORTANT: The fuel cylinder must be located within the limit of the machines counter weight.**

#### V. FOLLOW THESE INSTRUCTIONS BEFORE STARTING:

1. Reconnect battery cables and fill radiator, making sure all air is bled from the vaporizer.
2. Turn gas tank valves on slowly.
3. Check all lines for leaks. Use soap detector for gas.
4. Make sure the high pressure hose from bulkhead to lock off has maximum clearance for the hood.

#### IV. OPERATION

Once the engine is running and has warmed up to operating temperatures, the idle and power adjustments must be made as the follows:

##### IDLE ADJUSTMENT

(Adjustment located on side of carburetor)

##### IN RICH

##### OUT LEAN

1. Timing 8° BTC.
2. RPM 550 – Use tachometer.
3. Adjust carburetor to ½% of 1% on CO% meter per 550 RPM.
4. Exhaust analyzer 14.5 – 14.8 gasoline scale.
5. If CO% meter or exhaust analyzer is not available, use vacuum gauge and set at highest manifold vacuum at manufacturers idle RPM specs.

##### LOAD OR POWER ADJUSTMENT

(Adjustment located at under side of gas inlet)

1. Using tach with no load, make sure governor RPM are set at manufacturer specs. Return to idle.
2. Reaccelerate engine to approx. 100 to 150 rpm's below governor and if possible, pull tilt mask back to throw load on engine. Set power adjustment to highest RPM staying in the ½ to 1% CO reading or 14.1 to 14.5 on exhaust analyzer scale.

## Terminator® Tune-up Specs/H20 – II (electronic ignition)

Timing: **3-8°** degrees

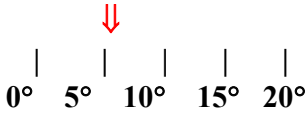

0° 5° 10° 15° 20°

RPM's: idle 900 to 1,000 rpm's

Spark Plug Gap: **.031"** to **.035"**  
 Bosch type B4ES, BPR4ES

Check spark plug electrodes for pitting. If pitting is present check LPG regulator for leaking gasket. [pitted spark plug electrodes are a indication of moisture in fuel]

Air Gap: **0.35 mm** to **0.45 mm**  
**0.0138"** to **0.0177"**

Measure air gap between signal rotor and pickup assembly.

Carb: idle adjustment; back out adjusting screw **2½** to **3** turns  
 Lean/Rich mixture adjustment under air horn should be set with a gas analyzer, allowing for the lowest emissions at the highest peak rpm performance. ( snap acceleration test )

here to here



R \ \ | / /L

Lean/Rich setting depends upon emission readings. It is recommended that a four or five gas analyzer be used in making this adjustment. Each time after adjusting the mixture wait 6 to 15 seconds before reading the analyzer.

If problems still persist, the carburetor should be taken apart and cleaned. The venturi plunger should move up and down freely without sticking. Check propane regulator.

Innovatech Products & Equipment Co., Inc.  
 19722 144<sup>th</sup> AVE. NE  
 WOODINVILLE, WA 98072  
 Phone: 1-425-402-1881 FAX: 1-425-402-8547  
 1-800-267-6682  
 Email: sales@the-terminator.com

TuneII.doc

**Trouble Shooting Guide**

Condition	Probable Cause	Corrective Action
Cannot crank Engine or Slow Cranking	Discharged Battery Loose alternator belt Ignition switch starter charging system Wiring	Charge Battery or Replace Adjust replace or repair replace or repair test; replace or repair inspect
Engine will crank but will not start	No fuel in propane cylinder Propane cylinder valve turned off No spark Idle adjustment incorrect Fast idle adjustment incorrect	check and fill turn on check coil, distributor, ignition switch adjust adjust
Engine hesitation Improper idle	Idling adjustment incorrect Dirty carburetor Carburetor/ manifold gasket Improper tightening of Manifold/carburetor Carburetor plunger sticks	adjust clean replace tighten clean
Excessive fuel consumption	Idle adjustment incorrect Worn parts	adjust service tune-up
Overheating	Radiator choked with dust  Loose fan belt Internal restriction of radiator dirty fluid Inaccurate temperature gauge water pump failure	Clean out air passage through fins with low water or air pressure tighten flush out flush and replace replace replace



### Blade Selection Guide

<u>Part #</u>	<u>Blade Description</u>	<u>Material</u>
TW-1001	4 X 9 X .074	vct,vat, elastomerics, rescrape glue
TW-1001-S/N	4 X 9 X .074 W/ NOTCH	
TW-1001-SSD	4 X 9 X .074 W/ NOTCH SD	
TW-1005	4 X 9 X .092	vct,vat, elastomerics, rescrape glue, wood, ceramic thinset
TW-1005-S/N	4 X 9 X .092 W/ NOTCH	
TW-1005-SSD	4 X 9 X .092 W/ NOTCH/SD	
TW-1010	4 X 13 X .074	vct,vat, elastomerics, rescrape glue, wood, ceramic thinset
TW-1010-S/N	4 X 13 X .074 W/ NOTCH	
TW-1010-SSD	4 X 13 X .074 W/ NOTCH/SD	carpet, vinyl, rubber
TW-1015	4 X 13 X .092	vct,vat, elastomerics, rescrape glue, wood, ceramic thinset
TW-1015-S/N	4 X 13 X .092 W/ NOTCH	
TW-1015-SSD	4 X 13 X .092 W/ NOTCH/SD	carpet, vinyl, rubber, elastomerics
TW-1020	4 X 18 X .074	vct,vat, carpet clean up, rescrape glue
TW-1020-S/N	4 X 18 X .074 W/ NOTCH	
TW-1020-SSD	4 X 18 X .074 W/ NOTCH/SD	carpet, vinyl, rubber
TW-1025	4 X 18 X .092	vct,vat, elastomerics, rescrape glue,
TW-1025-S/N	4 X 18 X .092 W/ NOTCH	
TW-1025-SSD	4 X 18 X .092 W/ NOTCH/SD	carpet, vinyl, rubber
TW-1030	4 X 26 X .074	vct,vat, carpet clean up, rescrape glue
TW-1030-S/N	4 X 26 X .074 W/ NOTCH	
TW-1030-SSD	4 X 26 X .074 W/ NOTCH/SD	carpet, vinyl
TW-1035	4 X 26 X .092	vct,vat, elastomerics, rescrape glue, wood, ceramic, thinset
TW-1035-S/N	4 X 26 X .092 W/ NOTCH	
TW-1035-SSD	4 X 26 X .092 W/ NOTCH/SD	carpet, vinyl
TW-2025-S/N	6 X 18 X .092 W/ NOTCH	double-layered tile, carpet
TW-2035-S/N	6 X 26 X .092	carpet, ceramic tile, double-layered vct, wood
TW-3005	4 1/2 X 10 X .125	ceramic thinset, double-layered vct, wood
TW-3015	4 1/2 X 13 X .125	
TW-3035	4 1/2 X 26 X .125	
TW-3045-S/N	9 X 26 X .125 W/ NOTCH	
AC2-029	small tile tooth	epoxy, urethane, mosaic tile, quarry tile, pavers porcelain, wood
AC2-019	large tile tooth	

**NOTE:** Blade selection depends entirely upon the material to be removed and the type of adhesive used to adhere the floor covering or coating to the concrete. The tougher the material, the smaller blade will be more effective in removing the material or adhesive.

Notched self-dicing (SD) blades can be used to ditch (skip rows) the material or using only one side (not skipping rows). If a blade smaller than 9 inches is required to successfully remove material, it is suggested that a 9 or 13 inch blade be cut down, leaving the blade a full 9 or 13 inches where it will be clamped into the jaw.

**Terminator® Maintenance Schedule**

<b><u>NUMBER OF HOURS*</u></b>	<b><u>DATE</u></b>	<b><u>SUGGESTED MAINTENANCE PROCEDURES</u></b>	<b><u>ACTUAL MAINTENANCE PROCEDURES</u></b>
10		Change Air Filter	
20			
30		Change Air Filter, Grease Fittings	
40			
50		Change Air Filter	
60		Change Hydraulic Oil Filter Canister and Oil, Check Wheel Hubs	
70		Change Air Filter	
80			
90		Change Air Filter, Grease Fittings	
100			
110		Change Air Filter	
120		Change Hydraulic Oil Filter Canister and Oil, Check Wheel Hubs, Grease Fittings	
130		Change Air Filter	
140			
150		Change Air Filter, Grease Fittings	
160			
170		Change Air Filter	
180		Change Hydraulic Oil Filter Canister and Oil, Check Wheel Hubs, Grease Fittings	
190		Change Air Filter	
200			
210		Change Air Filter, Grease Fittings	
220			
230		Change Air Filter	
240		Change Hydraulic Oil Filter Canister and Oil, Check Wheel Hubs, Grease Fittings	
250		Change Air Filter	
260			
270		Change Air Filter, Grease Fittings	
280			
290		Change Air Filter	
300		Change Hydraulic Oil Filter Canister and Oil, Check Wheel Hubs, Grease Fittings	

\*Number of hours and changes may vary depending on job quality.

## MATERIAL SAFETY DATA SHEET

### A. PRODUCT IDENTIFICATION AND EMERGENCY INFORMATION

PRODUCT NAME: **NUTO H 46** PRODUCT CODE: 363012  
 PRODUCT CATEGORY: Petroleum Lubricating Oil  
 PRODUCT APPEARANCE AND ODOR: clear liquid; yellow color; mild; bland petroleum odor  
 MEDICAL EMERGENCY TELEPHONE NUMBERS: 911  
 TRANSPORTATION EMERGENCY TELEPHONE NUMBERS: 911  
 FOR PRODUCT INFORMATION AND TECHNICAL ASSISTANCE CALL: 1-800-443-9966

For an MSDS or assistance with an MSDS, direct inquiries to the address below or call:

Marketing Technical Services  
 EXXON Company, USA  
 Room 2344  
 P.O. Box 2180  
 Houston, TX 77252-2180  
 (713) 656-5949

### B. COMPONENTS AND HAZARD INFORMATION

COMPONENTS	CASE NO. OF COMPONENTS	APPROXIMATE CONCENTRATION
Distillates (petroleum), hydro treated heavy paraffin	64742-54-7	Greater than 99%
OR	OR	
Distillates (petroleum), solvent dewaxed Heavy paraffin	64742-65-0	
Proprietary additives	Mixture	Less than 1%

This product, as manufactured by EXXON, doesn't not contain polychlorinated biphenyl (PCB's).

All components of this product are listed on the US TSCA inventory.  
 See Section E for Health and Hazard Information.  
 See Section H for additional Environmental Information.

#### HAZARDOUS MATERIALS IDENTIFICATION SYSTEM (HMIS)

Health	Flammability	Reactivity	BASIS
1	1	0	Recommended by Exxon

EXPOSURE LIMIT FOR TOTAL PRODUCT  
 5mg/m<sup>3</sup> for oil mist (aerosol) for an 8 hr. Workday

BASIS  
 OSHA Regulation 29 CFR1910.000 and recommended by the American Conference of Governmental Industrial Hygienists (ACGIH). ACGIH states that the air is to be sampled by a method that does not collect vapor; in addition, it lists a 10 mg/m<sup>3</sup> STEL.

### C. PRIMARY ROUTES OF ENTRY AND EMERGENCY AND FIRST AID PROCEDURES

**EYE CONTACT**

If splashed into the eyes, flush with clear water for 15 minutes or until irritation subsides. If irritation persists, call a physician.

**SKIN**

In case of skin contact, remove any contaminated clothing and wash skin with soap and water. Launder or dry-clean clothing before reuse. If product is injected into or under the skin, or into any part of the body, regardless of the appearance of the wound or its size, the individual should be evaluated immediately by a physician as a surgical emergency. Even though initial symptoms from high pressure injection may be minimal or absent, early surgical treatment within the first few hours may significantly reduce the ultimate extent of injury.

**INHALATION**

Vapor pressure is very low. Vapor inhalation under ambient conditions is normally not a problem. If overcome by vapor from hot products, immediately remove from exposure and call a physician. If breathing is irregular or has stopped, start resuscitation; administer oxygen, if available. If overexposed to oil mist, remove from further exposure until excessive oil mist condition subsides.

**INGESTION**

If ingestion, DO NOT induce vomiting; call a physician immediately.

**D. FIRE AND EXPLOSION HAZARD INFORMATION**

FLASH POINT (MINIMUM): 208°C (406°F); ASTM D92, Cleveland Open Cup

AUTO IGNITION TEMPERATURES: Greater than 260°C (500°F)

**NATIONAL FIRE PROTECTION ASSOCIATION (NFPA) - HAZARD IDENTIFICATION**

Health	Flammability	Reactivity	BASIS
1	1	0	Recommended by EXXON

**HANDLING PRECAUTIONS**

Use product with caution around heat, sparks, pilot lights, static electricity, and open flame.

**FLAMMABLE OR EXPLOSIVE LIMITS (APPROXIMATE PERCENT BY VOLUME IN AIR)**

Estimated values: Lower Flammable Limit - 0.9%      Upper Limit - 7%

**EXTINGUISHING MEDIA AND FIRE FIGHTING PROCEDURES**

Foam, water spray (fog), dry chemical, carbon dioxide and vaporizing liquid type extinguishing agents may all be suitable for extinguishing fires involving this type of product, depending on size or potential size of fire and circumstances related to the situation. Plan fire protection and response strategy through consultation with local fire protection authorities or appropriate specialists.

The following procedures for this type of product are based on the recommendations in the National Fire Protection Association's "Fire Protection Guide on Hazardous Materials." Tenth Edition (1991).

Use water spray, dry chemical, foam or carbon dioxide to extinguish the fire. Use water to keep fire-exposed containers cool. If a leak or spill has not ignited, use water spray to disperse the vapors and to provide protection for persons attempting to stop a leak. Water spray may be used to flush spills away from exposures. Minimize breathing of gases, vapor, fumes or decomposition products. Use supplies-air breathing equipment for enclosed or confined spaces or as otherwise needed.

**DECOMPOSITION PRODUCTS UNDER FIRE CONDITIONS**

Fumes, smoke, carbon monoxide, sulfur oxides, phosphorus oxides, metal oxides, aldehydes and other decomposition products, in the case of incomplete combustion.

**"EMPTY" CONTAINER WARNING**

"Empty" containers retain residue (liquid and/or vapor) and can be dangerous. DO NOT PRESSURIZE, CUT, WELD, BRAZE, SOLDER, DRILL, GRIND OR EXPOSE SCCH CONTAINERS TO HEAT, FLAME, SPARKS, STATIC ELECTRICITY, OR OTHER SOURCES OF IGNITION; THEY MAY EXPLODE AND CAUSE INJURY OR DEATH.

Do not attempt to refill or clean containers since residue is difficult to remove. "Empty" drums should be completely drained, properly bunged and promptly returned to a drum reconditioner. All other containers should be disposed of in an environmentally safe manner and in accordance with governmental regulations.

For work on tanks refer to Occupational Safety and Health Administration regulations, ANSI Z49.1, and other governmental and industrial references pertaining to cleaning, repairing, welding, or other contemplated operations.

## E. HEALTH AND HAZARD INFORMATION

### VARIABILITY AMONG INDIVIDUALS

Health studies have shown that many petroleum hydrocarbons and synthetic lubricants pose potential human health risks which may vary from person to person. As a precaution, exposure to liquids, vapors, mists or fumes should be minimized.

### EFFECTS OF OVEREXPOSURE (Signs and symptoms of exposure)

Prolonged or repeated skin contact may cause skin irritation.

### NATURE OF HAZARD AND TOXICITY INFORMATION

Repeated and prolonged overexposure to oil mists may result in droplet deposition, oil granuloma formation, inflammation and increased incidence of infection.

In accordance with the current OSHA Hazard Communication Standard criteria, this product does not require a cancer hazard warning. This is because the product is formulated from base stocks which are severely hydrotreated, severely solvent extracted, and/or processed by mild hydrotreatment and extraction. Alternatively, it may consist of components not otherwise affected by LARC criteria, such as atmospheric distillates or synthetically derived materials, and as such is not characterized by current ARC classification criteria.

Prolonged or repeated skin contact with this product tends to remove skin oils, possibly leading to irritation and dermatitis; however, based on human experience and available toxicological data, this product is judged to be neither a "corrosive" nor an "irritant" by OSHA criteria.

Product contacting the eyes may cause eye irritation.

Product has a low order of acute oral and dermal toxicity, but minute amounts aspirated into the lungs during ingestion of vomiting may cause mild to severe pulmonary injury and possibly death.

This product is judged to have an acute oral LD50 (rat) greater than 5 g/kg of body weight, and an acute dermal LD50 (rabbit) greater than 3.16 g/kg of body weight.

### PRE-EXISTING MEDICAL CONDITIONS WHICH MAY BE AGGRAVATED BY EXPOSURE

None recognized

## F. PHYSICAL DATA

The following data are approximate of typical values and should not be used for precise design purposes.

BOILING RANGE: ISP Approximately 293°C (560°F) by ASTM D 2887

VAPOR PRESSURE: Less than 0.01 mm @ 20°C

SPECIFIC GRAVITY (15.6°C/15.6°C): 0.88

VAPOR DENSITY (AIR – 1): Greater than 5

MOLECULAR WEIGHT: Not determined

PERCENT VOLATILE BY VOLUME: Negligible from open container in 4 hrs. @ 38°C (100°F)

pH: Essentially neutral

EVAPORATION RATE @ 1 ATM, and 25°C (77°F) (n-BUTYL = 1): Less than 0.01

POUR CONGEALING OR MELTING POINT: -30°C (-22°F): Pour Point by ASTM D 97

SOLUBILITY IN WATER @ 1 ATM AND 25°C (77°F): Negligible; less than 0.1%

VISCOSITY: 44 cSt @ 40°C

## G. REACTIVITY

This product is stable and will not react violently with water. Hazardous polymerization will not occur. Avoid contact with strong oxidants such as liquid chlorine, concentrated oxygen, sodium hypochlorite, calcium hypochlorite, etc., as this presents a serious explosion hazard.

## H. ENVIRONMENTAL INFORMATION

### CLEAN WATER ACT / OIL POLLUTION ACT

This product may be classified as an oil under Section 311 of the Clean Water Act, and under the Oil Pollution Act. Discharges or spills into or leading to surface waters that cause a visible sheen must be reported to the National Response Center (1-800-424-8802).

### STEPS TO BE TAKEN IN CASE MATERIAL IS RELEASED OR SPILLED

Recover free product. Add sand, earth or other suitable absorbent to spill area. Minimize breathing vapors. Minimize skin contact. Open all windows and doors. Keep product out of sewers and watercourses by diking or impounding. Advise authorities if product has entered or may enter sewers, watercourses, or extensive land areas.

Assure conformity with applicable governmental regulations.

THE FOLLOWING INFORMATION MAY BE USEFUL IN COMPLYING WITH VARIOUS STATE AND FEDERAL LAWS AND REGULATIONS UNDER VARIOUS ENVIRONMENTAL STATUTES:

THRESHOLD PLANNING QUANTITY (TPQ), EPA REGULATION 40 CFR 355 (SARA Sections 301-304); No TPQ for product or any constituent greater than 1% (carcinogen).

TOXIC CHEMICAL RELEASE REPORTING, EPA REGULATION 40 CFR 372 (SARA Section 313); No toxic chemical is present greater than 1% or 0.1% (carcinogen).

HAZARDOUS CHEMICAL REPORTING, EPA REGULATION 40 CFR 370 (SARA Section 311-312); EPA Hazard Classification Code: Not Applicable

### TOXIC SUBSTANCES CONTROL ACT

This product contains the following TSCA 12b reportable chemical substance(s): 2-Ethylhexanol CAS # 104-76-4.

## I. PROTECTION AND PRECAUTIONS

### VENTILATION

Use local exhaust to capture vapor, mists or fumes, if necessary. Provide ventilation sufficient to prevent exceeding recommended exposure limit or buildup of explosive concentration of vapor in air. No smoking, or use of flame or other ignition sources.

### RESPIRATORY PROTECTION

Use supplied-air respiratory protection in confined or enclosed spaces, if needed

### PROTECTIVE GLOVES

Use chemical-resistant gloves, if needed, to avoid prolonged or repeated skin contact.

### EYE PROTECTION

Use splash goggles or face shield when eye contact may occur.

### OTHER PROTECTIVE EQUIPMENT

Use chemical-resistant apron or other impervious clothing, if needed, to avoid contaminating regular clothing, which could result in prolonged or repeated skin contact.

### WORK PRACTICES / ENGINEERING CONTROLS

To prevent fire or explosion risk from static accumulation and discharge, effectively bond and/or ground product transfer system in accordance with the National Fire Protection Association PUBLICATIONS.

Keep containers closed when not in use. Do not store near heat, sparks, flame or strong oxidants.

In order to prevent fire or explosion hazards, use appropriate equipment/

Information on electrical equipment appropriated for use with this product may be found in the latest edition of the National Electrical Code (NFPA-701). This document is available from the National Fire Protection Association.

#### PERSONAL HYGIENE

Minimize breathing vapor, mist or fumes. Avoid prolonged or repeated contact with skin. Remove contaminated clothing; launder or dry-clean before re-use. Remove contaminated shoes and thoroughly clean before re-use; discard if oil-soaked. Cleanse skin thoroughly after contact, before breaks and meals, and at end of work period. Product is readily removed from skin by waterless hand cleaners followed by washing thoroughly with soap and water.

### J. TRANSPORTATION AND OSHA RELATED LABEL INFORMATION

#### TRANSPORTATION INCIDENT INFORMATION

For further information relative to spills resulting from transportation incidents, refer to latest Department of Transportation Emergency Response Guidebook for Hazardous Material Incidents.

U.S. DOT HAZARDOUS MATERIALS SHIPPING DESCRIPTION: Not Regulated

#### OSHA REQUIRED LABEL INFORMATION

In compliance with hazard and right-to-know requirements, where applicable OSHA Hazard Warnings may be found on the label, bill of lading or invoice accompanying this shipment.

Note: Product label may contain non-OSHA related information also.

The health and safety information presented herein must be used in conjunction with the pertinent standards for training, work practices and facilities design established by OSHA, NIOSH, NFFA, API, NEC, NSC, UNDERWRITERS, BUREAU OF MINES, and similar organizations.

The information and recommendations contained herein are, to the best of EXXON's knowledge and belief, accurate and reliable as of the date issued. EXXON does not warrant or guarantee their accuracy or reliability, and Exxon shall not be liable for any loss or damage arising out of the use thereof.

The information and recommendations are offered for the user's consideration and examination, and it is the user's responsibility to satisfy itself that they are suitable and complete for its particular use. If buyer repackages this product and other necessary information is included on the container.

The Environmental Information included under Section H hereof as well as the Hazardous Materials Identification System (HMIS) and National Fire Protection Association (NFPA) rating have been included by Exxon Company, USA in order to provide additional health and hazard classification information. The ratings recommended are based upon the criteria by the developers of these rating systems, together with Exxon's interpretation of the available data.

## MATERIAL SAFETY DATA SHEET

An explanation of the terms herein may be found in OSHA CFR 1910.1200,  
available from OSHA regional or area offices.

**(Essentially similar to U.S. Department of Labor Form OSHA-20  
and generally accepted in Canada for information purposes.)**

### A. PRODUCT IDENTIFICATION

PRODUCT: Propane

CHEMICAL NAME: Propane

FORMULA: C<sub>3</sub>H<sub>8</sub>

TRADE NAME: Liquefied Petroleum Gas

SYNONYMS: Dimethylmethane, Propyl Hydride, Propylhydride

CHEMICAL FAMILY: Alkane

MOLECULAR WEIGHT: 44.096

### B. HAZARDOUS INGREDIENTS

MATERIAL (CASE NO.) Propane (74-98-6)

Weight (%): 100

1984-1985 ACGIH TLV-TWA (OSHA-PEL): Simple asphyxiant (1000ppm)

### C. PHYSICAL DATA

BOILING POINT, 760mm, Hg: -42.1°C (-43.7°F)

FREEZING POINT: -187.7°C (-305.8°F)

SPECIFIC GRAVITY (H<sub>2</sub>O = 1): 0.5077 @ 25°C

VAPOR PRESSURE AT 21°C: 109psig

VAPOR DENSITY (air = 1): 1.55 @ 20°C

SOLUBILITY IN WATER, % by wt.: Negligible

PERCENT VOLATILES BY VOLUME: 100

EVAPORATION RATE (Butyl Acetate = 1): High

APPEARANCE AND ODOR: Colorless gas at normal temperature and pressure; faintly disagreeable odor.

### EMERGENCY PHONE NUMBER

In Case of EMERGENCIES involving this material, further information is available at all times:

In the USA (304)744-3487

In CANADA (514)514-5311

For routine information contact your local supplier.

Union Carbide requests the users of this product to study this Material Safety Data Sheet (MSDS) and become aware of product hazards and safety information. To promote safe use of this product a user should 1. Notify its employees, agents and contractors of the information on this MSDS and any product hazards and safety information, 2. Furnish this same information to each of its customers for the product, and 3. Request such customers to notify their employees and customers for the product of the same product hazards and safety information.

**UNION CARBIDE CORPORATION □ LINDE DIVISION  
UNION CARBIDE CANADA LIMITED □ LINDE DIVISION**

### D. HEALTH HAZARD DATA

EFFECTS OF SINGLE (ACUTE) OVEREXPOSURE:

SWALLOWING—This product is a gas at normal temperature and pressure.

SKIN ABSORPTION—No evidence of adverse effects from available information.

INHALATION—Asphyxiant. Moderate concentrations may cause headache, drowsiness, dizziness, excitation, excess salivation, vomiting, and unconsciousness. Lack of oxygen can cause death.

SKIN CONTACT—No harmful effect expected from vapor. Liquid may cause frostbite.

EYE CONTACT—No harmful effect expected from vapor. Liquid may cause frostbite.

EFFECTS OF REPEATED (CHRONIC) OVEREXPOSURE: No evidence of adverse effects from available information.

OTHER EFFECTS OF OVEREXPOSURE: Contact with liquid may cause frostbite.



**MEDICAL CONDITIONS AGGRAVATED BY OVEREXPOSURE:** A knowledge of the available toxicology information and of the physical and chemical properties of the material suggest that overexposure is unlikely to aggravate existing medical conditions.

**SIGNIFICANT LABORATORY DATA WITH POSSIBLE RELEVANCE TO HUMAN HEALTH HAZARD EVALUATION:** None currently known.

**EMERGENCY AND FIRST-AID PROCEDURES:**

**SWALLOWING**—This product is a gas at normal temperature and pressure.

**SKIN CONTACT**—For exposure to liquid, immediately warm frostbite area with warm water (not to exceed 105°F), in case of massive exposure, remove clothing while showering with warm water. Call a physician.

**INHALATION**—Remove to fresh air. Give artificial respiration if not breathing. Give oxygen if breathing is difficult. Call a physician.

**EYE CONTACT**—In case of splash contamination, immediately flush eyes thoroughly with water for at least 15 minutes. See a physician, preferably an ophthalmologist, immediately.

*NOTES TO PHYSICIAN: There is no specific antidote. Treatment to overexposure should be directed at the control of symptoms and the clinical conditions.*

## **E. FIRE AND EXPLOSION HAZARD DATA**

**FLASH POINT:** -104°C (-156°F) TCC      **AUTOIGNITION TEMP:** 450°C (842°F)

**FLAMMABLE LIMITS IN AIR, %by volume:** Lower 2.01%; Upper 9.5%

**EXTINGUISHING MEDIA:** CO<sub>2</sub>, dry chemical, water spray or fog.

**SPECIAL FIRE FIGHTING PROCEDURES:**

Evacuate all personnel from danger area. Immediately cool containers with water spray from maximum distance taking care not to extinguish flames. Remove ignition sources if without risk. If flames are accidentally extinguished, explosive re-ignition may occur. Appropriate measures should be taken e.g., total evacuation. Reapproach with extreme caution. Use self-contained breathing apparatus. Stop flow of gas if without risk while continuing cooling water spray. Remove all containers from area of fire if without risk. Allow fire to burn out. On site fire brigades must comply with OSHA 29 CFR 1910.156.

**UNUSUAL FIRE AND EXPLOSION HAZARDS:**

Flammable gas. Forms explosive mixtures with air and oxidizing agents. Container may rupture due to heat of fire. Do not extinguish flames due to possibility of explosive re-ignition. Flammable vapors may spread from the spill. Explosive atmospheres may linger. Before entering area, especially confined areas, check atmosphere with approved device. No part of a container should be subjected to a temperature higher than 52°C (approximately 125°F).

Most containers are provided with a pressure relief device designed to vent contents when they are exposed to elevated temperature.

## **F. REACTIVITY DATA**

**STABILITY:** Stable

**INCOMPATIBILITY (material to avoid):** Oxidizing agents, chlorine dioxide

**HAZARDOUS DECOMPOSITION PRODUCTS:** Thermal decomposition or burning may produce CO/CO<sub>2</sub>.

**HAZARDOUS POLYMERIZATION:** Will not Occur

## **G. SPILL OR LEAK PROCEDURES**

**STEPS TO BE TAKEN IF MATERIAL IS RELEASED OR SPILLED:**

**DANGER:** Forms explosive mixtures with air (See Section E)

Immediately evacuate all personnel from danger area. Use self-contained breathing apparatus where needed. Remove all sources of ignition if without risk. Reduce vapors with fog or fine water spray. Shut off leak if without risk. Ventilate area

of leak or move leaking container to well-ventilated area. Flammable vapors may spread from spill. Before entering area, especially confined areas, check atmosphere with appropriate device.

#### WASTE DISPOSAL METHOD:

Prevent waste from contaminating surrounding environment. Keep personnel away. Discard any product, residue, disposable container or liner in an environmentally acceptable manner, in full compliance with Federal, state and local regulations.

### H. SPECIAL PROTECTION INFORMATION

RESPIRATORY PROTECTION (specify type): Select in accordance with OSHA 29 CFR 1910.134. Respirators shall be acceptable to MSHA and NIOSH.

#### VENTILATION

LOCAL EXHAUST—Explosion-proof system is acceptable. See “SPECIAL.”

MECHANICAL (general)—Inadequate. See “SPECIAL.”

SPECIAL—Use in a closed system.

OTHER—See “SPECIAL.”

PROTECTIVE GLOVES: Preferred for cylinder handling and to prevent liquid exposure.

EYE PROTECTION: Select in accordance with OSHA 29 CFR 1910.33.

OTHER PROTECTIVE EQUIPMENT: Metatarsal shoes for cylinder handling. Protective clothing where needed. Select in accordance with OSHA 29 CFR 1910.132 and 1910.133.

### I. SPECIAL PRECAUTIONS

**DANGER:** Flammable, liquefied gas under pressure.

Use piping and equipment adequately designed to withstand pressures to be encountered. May form explosive mixtures with air. Ground all equipment. Only use spark-proof tools and explosion-proof equipment. Keep away from heat, sparks, and open flame. Store and use with adequate ventilation at all times. Use only in a closed system. Close valve when not in use and when empty. Keep away from oxidizing agents.

MIXTURES: When two or more gases, or liquefied gases are mixed, their hazardous properties may combine to create additional, unexpected hazards. Obtain and evaluate the safety information for each component before you produce the mixture. Consult an industrial Hygienist, or other trained person when you make your safety evaluation of the end product. Remember, gases and liquids have properties which can cause serious injury or death.

Be sure to read and understand all labels and other instructions supplied with all containers of this product.

*Note: Compatibility with plastics should be confirmed prior to use. For safety information on general handling of compressed gas cylinders, obtain a copy of pamphlet P-1, “Safe Handling of Compressed Gases in Containers” from the Compressed Gas Association, Inc., 1235 Jefferson Davis Highway, Arlington, VA 22202.*

OTHER HANDLING AND STORAGE CONDITIONS: Never work on a pressurized system. If there is a leak, close the cylinder valve, blow down the system by venting to a safe place, then repair the leak.

The opinions expressed herein are those qualified experts within Union Carbide. We believe that the information contained herein is current as of the date of this Material Safety Data Sheet. Since the use of this information and these opinions and the conditions of the use of the product are not within the control of Union Carbide, it is the user’s obligation to determine to condition of safe use of the product.

#### General Offices:

In the USA:  
Union Carbide Corporation  
Linde Division  
39 Old Ridgebury Road  
Danbury, CT 06817-0001

In Canada:  
Union Carbide Canada Limited  
Linde Division  
123 Eglinton Avenue East  
Toronto, Ontario M4P 1J3

### Propane Safety Precautions

Liquid petroleum gas (propane) is flammable and potentially explosive. ALWAYS obey proper handling, lighting and ventilating procedures provided by the manufacturer. In addition, obey the safety warnings and procedures below, which are provided to supplement, not replace or substitute for the manufacturer's instructions.

**WARNING!**

Wear insulated gloves when you handle propane tanks.

Do not attempt to adjust the pressure regulator because the manufacturer sets it. If adjustment is required, a qualified liquid petroleum gas service technician must make it.

Inspect the fuel lines and connectors before each job or at the beginning of the day, to detect any leaks or potential problems. NEVER check for propane leaks with an open flame.

NEVER use ammoniated household-type detergents to detect leaks or to clean any portion of the fuel system or the tank. These substances can cause cracks on brass fittings and on the fuel line. If the leak cannot be located, take the tank to a certified liquid petroleum gas service representative.

NEVER store or carry propane containers in a closed space or inside your passenger vehicle. Propane containers are equipped with safety devices that relieve excessive pressure by discharging gas to the atmosphere and leaks can occur at the fittings or connectors.

NEVER fill a tank more than 80% of capacity. Overfilling can cause uncontrolled gas flow, which in turn, can cause fire and/or explosion.

**IF YOU SMELL GAS**

1. Immediately extinguish any open flames, pilot lights and all smoking materials.
2. Turn the engine OFF; do not touch any electrical switches or other device that may produce sparks.
3. Shut OFF the fuel flow switch.
4. Open all doors and windows to allow maximum ventilation.
5. Leave the area until the odor clears.
6. Inspect the fuel lines and connectors to determine the source of the leak. Correct the problem before you use the Terminator again.

**ALL NEW PROPANE TANKS MUST BE PURGED BEFORE USE!**

## WARRANTY

Innovatech warrants to the original buyer for a period of one (1) year or 300 operating hours (whichever comes first) from the date of delivery that Equipment is free from defects in materials and workmanship and that the Equipment conforms to the operating specifications supplied with the Equipment. The foregoing warranty is subject to proper operation and maintenance of the Equipment in accordance with the operating instruction and manual supplied to Buyer with the Equipment.

Warranty claims shall be made by Buyer in writing. Innovatech's sole obligation under the foregoing warranty, where it appears to Innovatech's satisfaction that the defect was present at the time of delivery, is at Innovatech's sole option, to repair, replace or correct any such defect.

EXCEPT AS STATED ABOVE THERE ARE NO WARRANTIES, EXPRESS OR IMPLIED. INNOVATECH EXPRESSLY DISCLAIMS ANY WARRANTY, EXPRESS OR IMPLIED, THAT EQUIPMENT SOLD HEREUNDER IS OF MERCHANTABLE QUALITY OR THAT IT CAN BE USED FOR OR IS FIT FOR ANY PARTICULAR PURPOSE. ANY DESCRIPTION OF THE EQUIPMENT IN THIS AGREEMENT OR IN MANUALS, BROCHURES OR LITERATURE AND ANY USE OF ANY SAMPLE, MODEL OR PROTOTYPE OF THE EQUIPMENT IS FOR THE SOLE PURPOSE OF IDENTIFYING OR ILLUSTRATING THE EQUIPMENT, IS NOT PART OF THE BASIS OF THE AGREEMENT BETWEEN INNOVATECH AND BUYER, AND DOES NOT CONSTITUTE A WARRANTY THAT THE EQUIPMENT, AS SUPPLIED, WILL CONFORM TO ANY DESCRIPTION OR TO ANY SAMPLE, MODEL OR PROTOTYPE. INNOVATECH DISCLAIMS ANY WARRANTY RESPECTING OPERATING CAPACITY OR CAPABILITY OF THE EQUIPMENT OR THE ABILITY OF THE EQUIPMENT TO MEET ANY PARTICULAR NEEDS OF THE BUYER. THE EQUIPMENT IS POWERED TO OPERATE AS STATED IN THE OPERATING SPECIFICATIONS SUPPLIED WITH THE EQUIPMENT BUT IT IS UNDERSTOOD AND AGREED TO BUY BUYER THAT ACTUAL OPERATING CAPABILITIES VARY UNDER DIFFERENT OPERATING CONDITIONS FOR WHICH INNOVATECH CAN ASSUME NO RESPONSIBILITY.

BUYER'S EXCLUSIVE REMEDY FOR CLAIMS ARISING UNDER THIS AGREEMENT SHALL BE FOR REPAIR OR, AT INNOVATECH'S SOLE OPTION, REPLACEMENT OF ANY ITEM OF DEFECTIVE EQUIPMENT. INNOVATECH'S LIABILITY FOR ANY LOSSES OR DAMAGE, WHETHER ON ACCOUNT OF NEGLIGENCE, BREACH, WARRANTY OR OTHERWISE SHALL IN NO EVENT EXCEED THE PURCHASE PRICE OF THE PARTICULAR ITEM OF EQUIPMENT WITH RESPECT TO WHICH SUCH LOSSES OR DAMAGE OCCURRED. IN NO EVENT WILL INNOVATECH BE LIABLE FOR ANY DAMAGES CAUSED BY BUYER'S FAILURE TO PERFORM BUYER'S RESPONSIBILITIES, OR FOR ANY LOST PROFITS, LOST PRODUCTION, LOSS OF ANTICIPATED PROFITS OF OTHER INCIDENTAL OR CONSEQUENTIAL DAMAGES, EVEN IF INNOVATECH HAS BEEN ADVISED OF THE POSSIBILITY OF SUCH DAMAGES. IN NO EVENT WILL INNOVATECH BE LIABLE FOR ANY DAMAGES RESULTING FROM ANY CLAIM AGAINST BUYER BY ANY OTHER PARTY.

## FACTORY SERVICE

A warranty will not be valid unless a written claim authorization comes with returned parts. Innovatech will not provide for any shipping costs for items returned for repair. To obtain warranty repairs, buyer must prepay shipment and return all warranty parts to Innovatech. Damage occurring during shipment is deemed the responsibility of the carrier and claims should be made directly with such carrier.

It will be the customer's responsibility to pay for any non-warranty replacement parts plus the current hourly labor rates for any work done on any machine or part. Service is available upon request; call Innovatech for current labor rates.

## TERMINATOR 2000 PARTS CATALOG



## Terminator 2000 Parts List

### T-2000 Hydraulic Assembly

Item	Part Number	Description	Notes
1	HYTL-006	Hydraulic Oil Chiller	
2	HAT-008	Hose Assy, Valve to Chiller	
3	HAT-001	Hose Assy, Chiller to Filter	
4	HYUF-014	Hyd. Fitting, 90°, 10-12-C50X-S	
5	HY2-008	Hydraulic Pump	
6	HY2F-016	Hyd. Fitting, 0588-16-16	
7	HY2F-017	Hyd. Fitting, 0188-16-16	
8	HYU-031	Hyd Fitting, 90° Street "L", 1"	
9	HYT-007	Hyd. Hose, Suction, 21.5"	
10	HA2-006	Hose Assy, Valve Top Center to Cylinder	
11	HA2-007	Hose Assy, Valve Bottom Center to Cylinder	
12	HYU-022R	Left/Right Control Handles	
13	HYUF-008	Hyd. Fitting 90°, 10-8 C50X-S	
14	HYU-022	Hydraulic Control Valve	
15	HAT-003	Hose Pump to Valve	
16	HY2F-001	Hyd Fitting, 6 F50X-S	
17	HYU-003	Hyd Fitting, Flow Reducer	
18	HYU-009H	Hyd Filter and Element	Elem only P/N HYU-010H
19	HY2F-013	Hyd. Fitting, 10-12 FTX-S	
20	HYUF-040	Hyd Fitting, 90°, 12-CTX-S	
21	HY2F-009	Hyd. Fitting, 12 FTX-S	
22	HAT-009	Hose Assy, Filter To Tank	
23	HA2-004	Hose Assy, Valve Top to Wheel Motor	
24	HA2-005	Hose Assy, Valve Bottom to Wheel Motor	
25	HY2HC-001	Hose Clamp, TBC 150 T	
26	HY2F-003	Hyd Fitting, 4-6 F50X-S	
27	HYU-022RC	Center, Control Handle	
28	HY2-004	Front Cylinder Assembly	Includes Tie Rods and Pins

# T-2000 HYDRAULIC ASSEMBLY

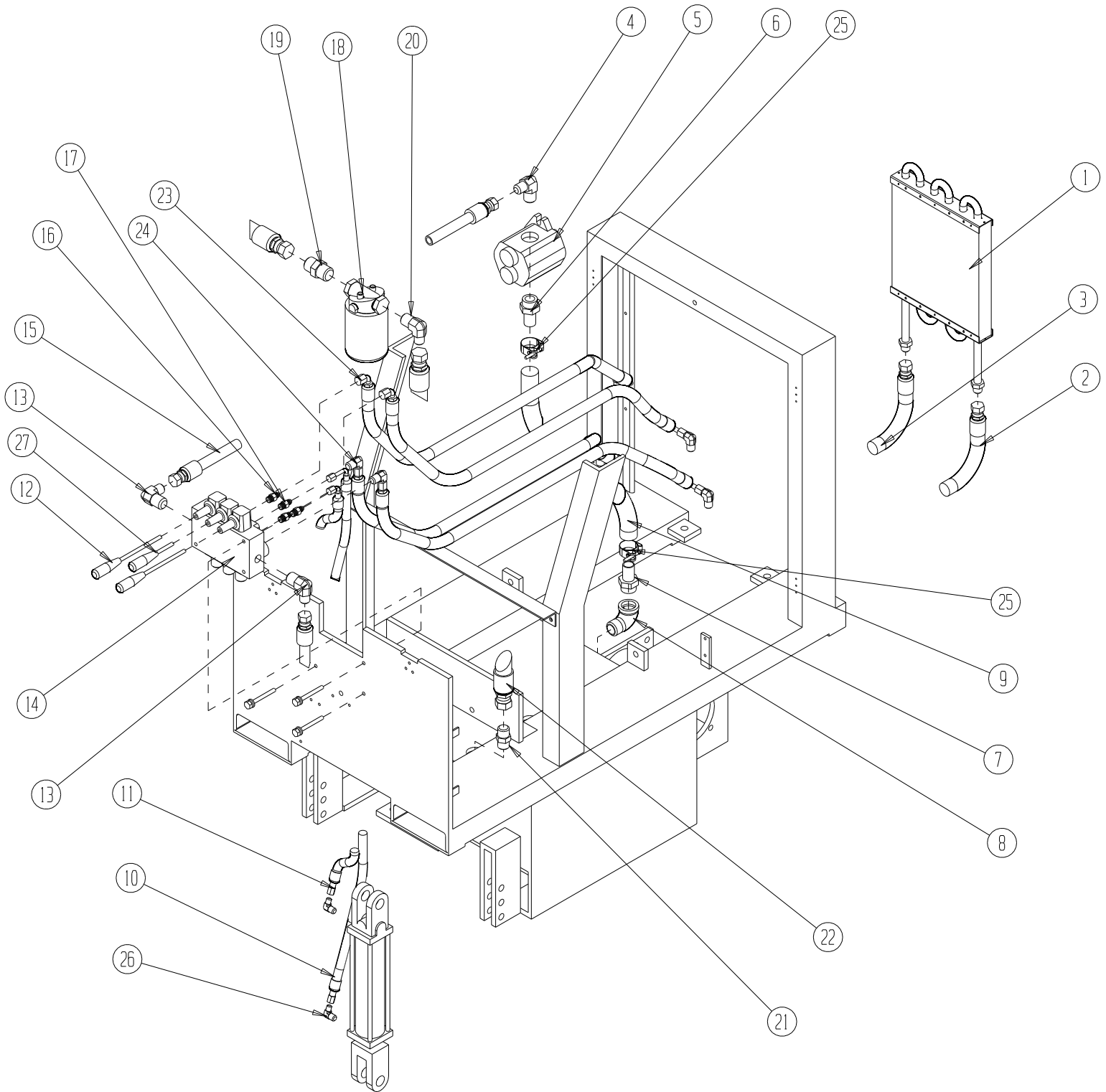

**T-2000 Engine Assembly**

Item	Part Number	Description	Notes
1	MET-014K	Nissan H20 Engine	
2	FS-0013	Engine Mount	
3	HD-011	Bolt, Hex Cap, 3/8-16 x 3-1/2"	
4	MET-006	Air Pump	
5	FS-0081	Air Pump Bracket, Upper	
6	MET-007	Catalytic Converter	
7	MET-055	Exhaust Pipe	
8	HD-031	Bolt, Hex Cap, M10 x1.5 x 25mm	With Lock washer
9	FS-0013	Engine Mount	
10	MET-049	Flywheel Guard	
11	HD-001	Bolt, Hex Cap, 5/16-18 x 1-1/2"	Incl. Washer and Nyloc Nut
12	HD-012	Bolt, Hex Cap, 3/8-16 x 4"	
13	HD-031	Bolt, M10 x1.5 x 25mm	
14	FS-0083	Air Pump Bracket, Lower	
15	HD-031	Bolt, Hex Cap, M10 x 1.5 x 25mm	With Lock Washer



# T-2000 Engine Assembly

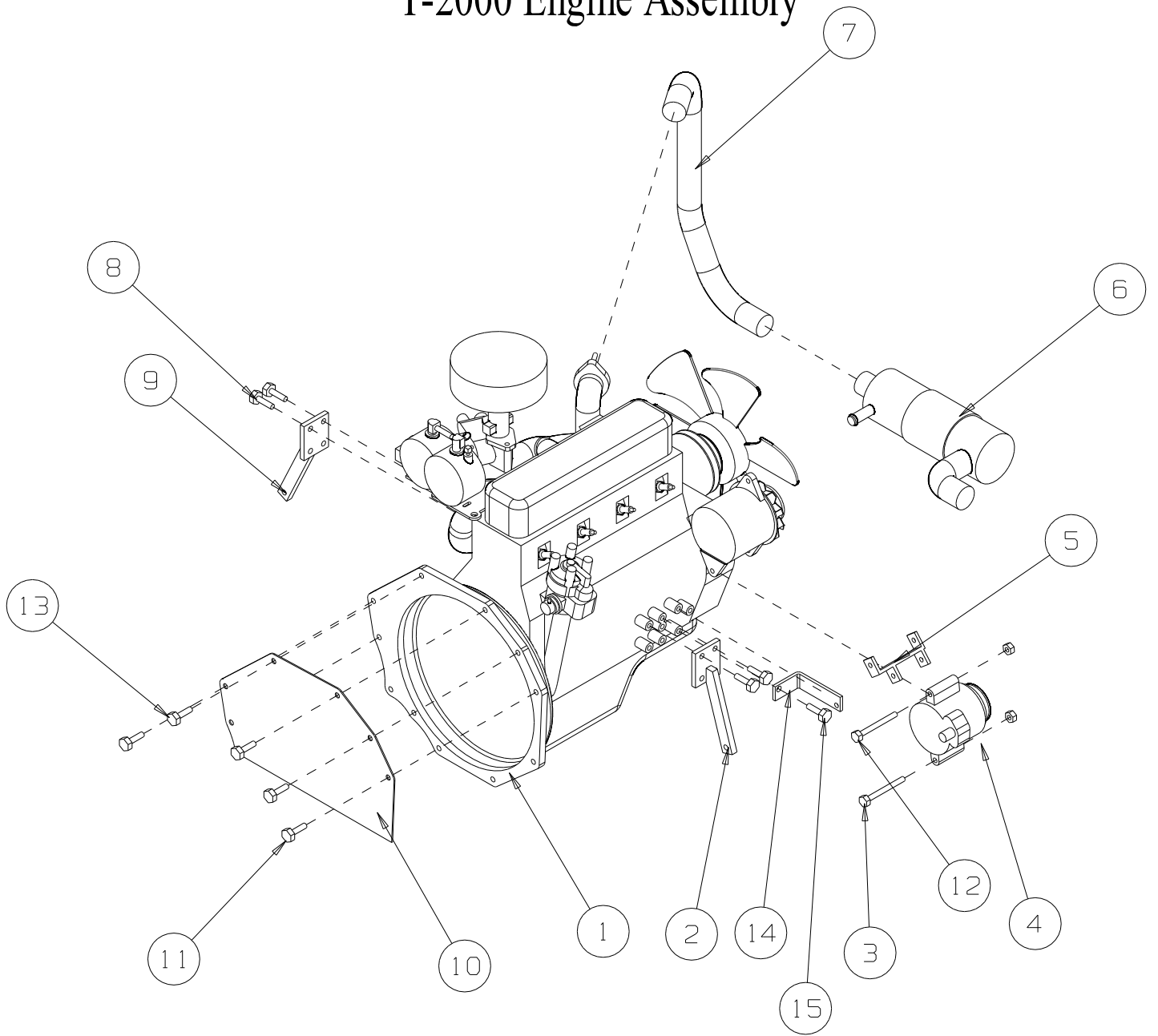

**T-2000 Front Console**

Item	Part Number	Description	Notes
1	MIU-012	Seat	
2	FS-0030-01	Seatbelt Bracket, Left	
3	MIU-013	Seat Belt	Both Sides, Includes Hardware
4	MET-010	Gauge Plate	
5	MITL-004	Compression Latch, Knob	Includes Attachment
7	ELTL-010	Hour Meter	
8	ELT-003	Charge Meter	
9	HD-019	Bolt, 1/2-13 x 1" Hex Cap	
10	ELTL-055	Headlight Switch	
12	ELTL-012	Ignition Switch	P/N ELTL-069 Keyed Version
13	ELTL-057	Alternator Light	
14	ELT-016	Engine Temp Gauge	
15	ELT-020	Oil Pressure Gauge	
16	ELT-016	Hydraulic Oil Temp Gauge	
17	HD-121	Bolt, 5/16-18 x 3/4", Flat HD Phil	
18	FS-0030-02	Seat Belt Bracket, Right	
19	MIU-004	Console Hinge	
20	HD-108	Screw, 8-32 x 3/4", Pan HD Phil	

# Front Console Assembly

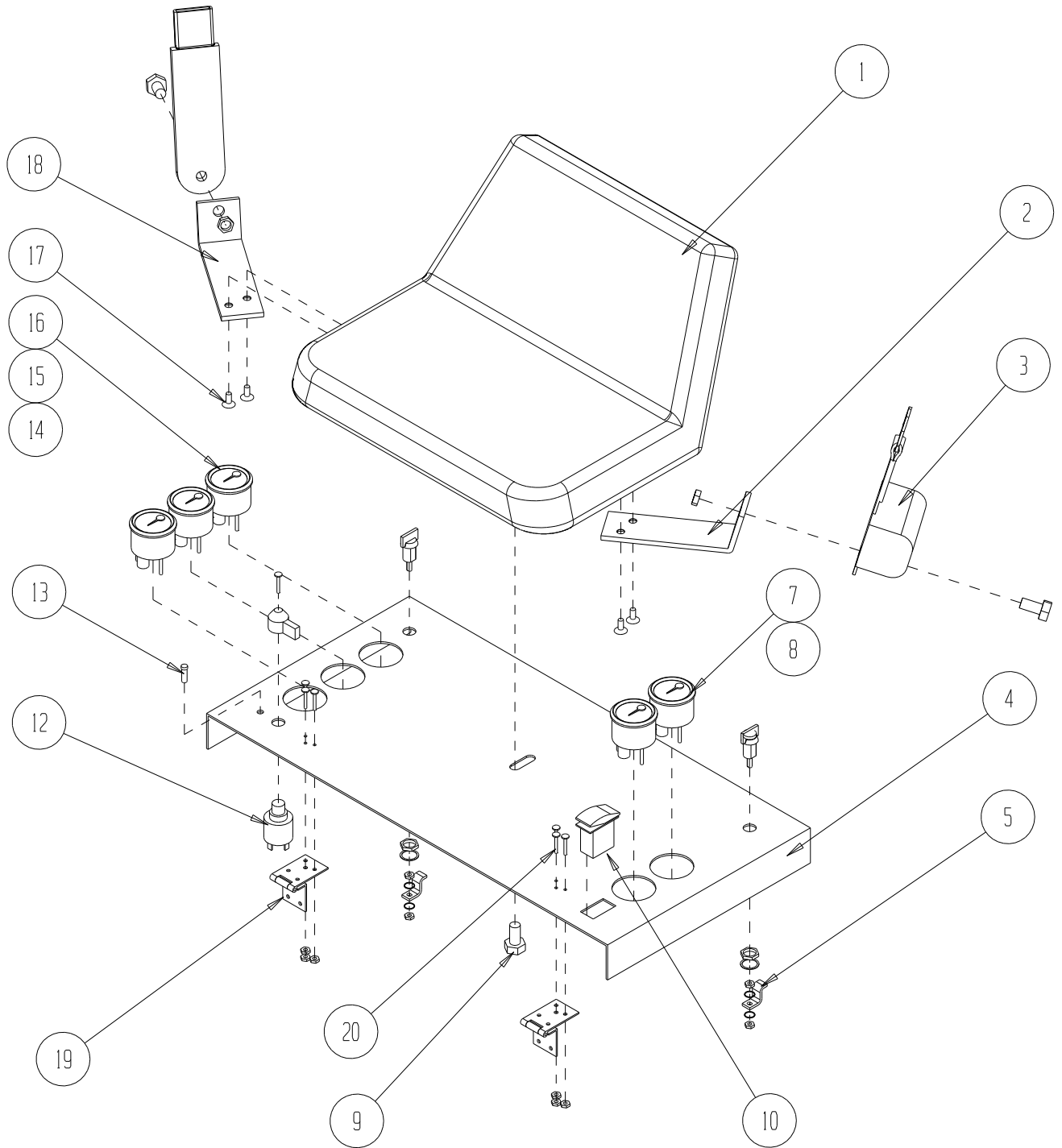

**T-2000 Wheel Motor Assembly**

Item	Part Number	Description	Notes
1	HD-023	Bolt, Hex Cap, ½-13 x 3	Includes Nut and Washer
2	MITE-019	Wheel Hub	
3	HYU-030	Pack Nut	Tighten to 375 Ft-lb.
4	MI3-002	Rear Wheel	
5	HD-065	Nut, ½-20, Nylok	
6	RPU-008	Woodruff Key	
7	HYTE-008L	Wheel Motor, Left	P/N HYTE-008R, Right Side

# Wheel Motor Assy

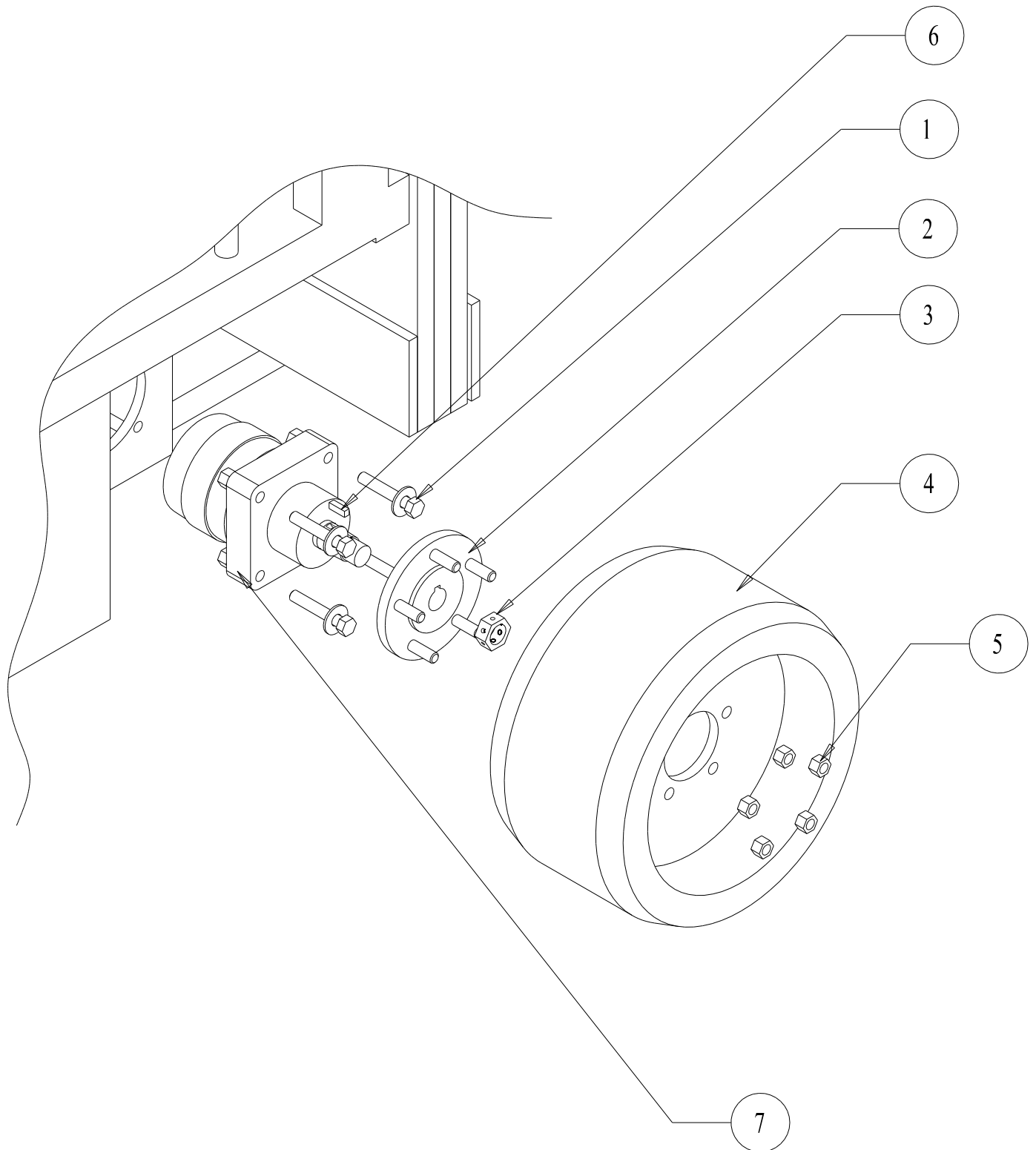

**T-2000 Top Cover Assembly**

Item	Part Number	Description	Notes
1	MET-008	Top Cover	
2	MIU-001	Cover Handle	
3	HD-112	Bolt, Flat HD, 1/4-20 x 3/4", flat	
4	PCTL-002	Fitting, Brass, "T"	Includes Nuts and Washers
5	PCTL-001	Bulkhead, Relief Valve	
6	PCTL-009	Fitting, Brass 90°	
7	PCTL-010	Fuel Hose Assembly	
8	PCTL-007	Fitting, Propane Tank	
9	ELU-014	Strobe Light	Including Attachment Hardware
10	MEU-006	Light Bracket	Including Attachment Hardware
11	MITL-008	Propane Tank Bracket	Including Attachment Hardware
12	MIU-011	Fire Extinguisher	Including Attachment Hardware

# Top Cover Assembly

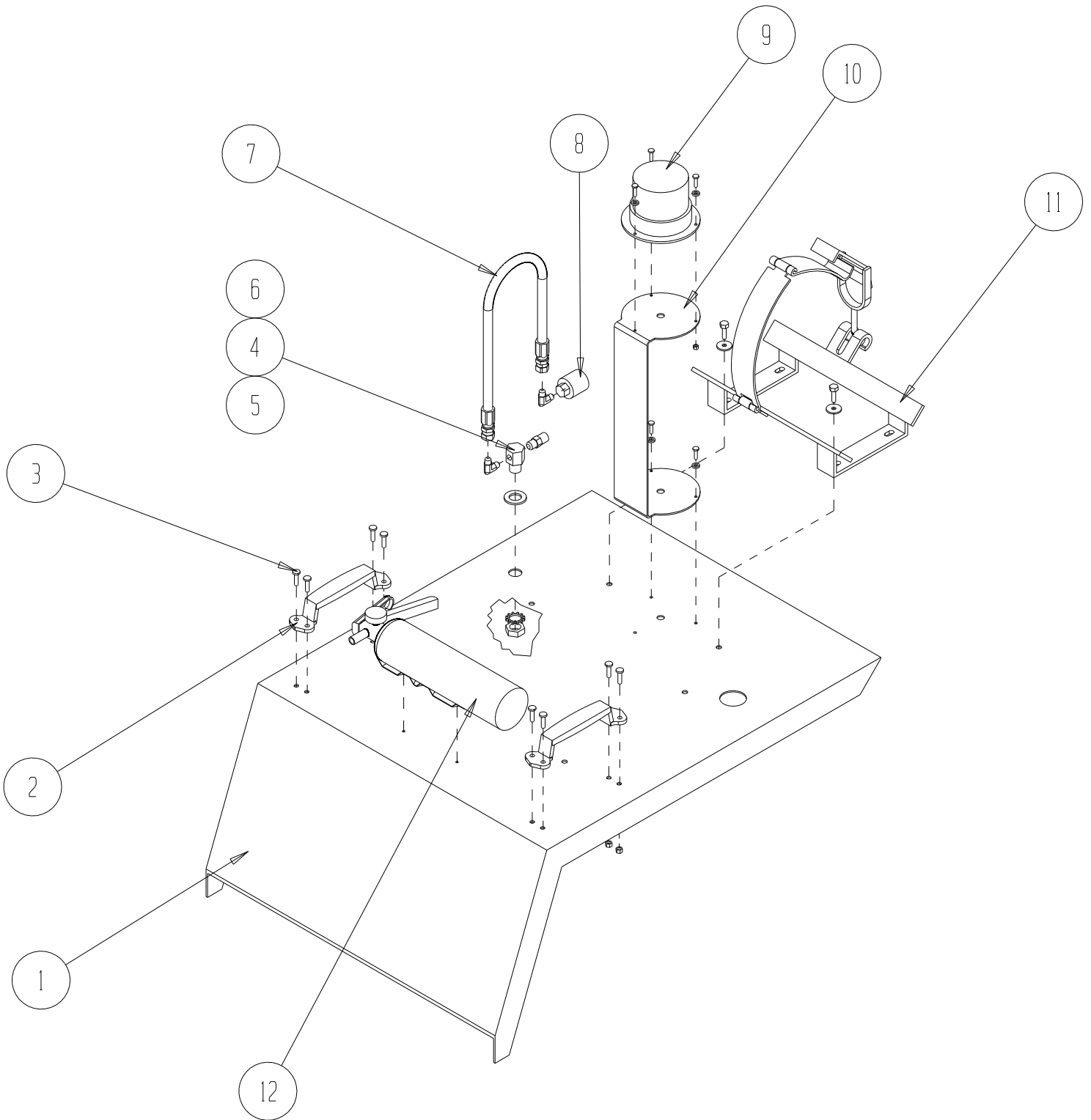

**T-2000 Door Assembly**

Item	Part Number	Description	Notes
1	SM-0001	Door, T-2000e, Right	P/N SM-0002 (Left)
2	MIU-014	Latch, Paddle, Spring Loaded	
3	MIU-007	Lift-off Hinge, Satin, Right	MIU-006 (Left Side)
4	HD-102	Screw, 6-32 x 3/4, Pan HD Phillips	
5	HD-050	Nut, 6-32, Nylok	



# Door Assembly

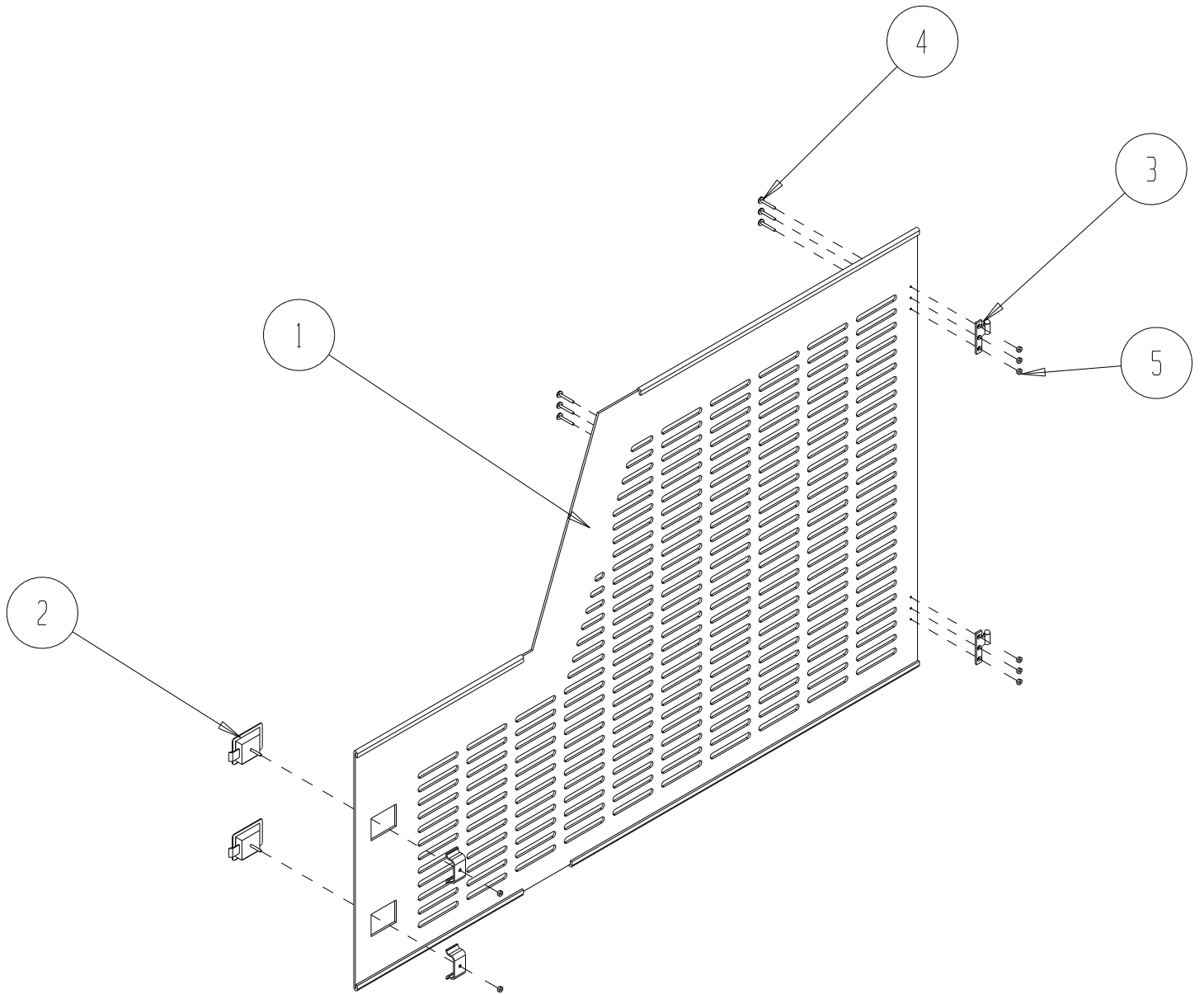

## **VISIT OUR INFORMATIVE ON-LINE STORE**

If you visit our home page, you will find information about our tools and machines.

[www.The-Terminator.com](http://www.The-Terminator.com)

---

# **INNOVATECH**

---

[sales@the-terminator.com](mailto:sales@the-terminator.com)  
19722 144th Avenue NE  
Woodinville, WA 98072, U.S.A.

